

# LATHE

## OPERATION MANUAL



**Models**  
**CL-410, CL-460**

*Edition No* : LM4101

*Date of Issue* : 10/2017

**MACHINE DETAILS**

<b>MACHINE</b>	<input type="text" value="METAL CUTTING LATHE"/>
<b>MODEL NO.</b>	<input type="text"/>
<b>SERIAL NO.</b>	<input type="text"/>
<b>DATE OF MANF.</b>	<input type="text"/>

Distributed by



[www.machineryhouse.com.au](http://www.machineryhouse.com.au)

[www.machineryhouse.co.nz](http://www.machineryhouse.co.nz)

**NOTE:**

This manual is only for your reference. Owing to the continuous improvement of the machine, changes may be made at any time without obligation or notice. Please ensure the local voltage is the same as listed on the specification plate before operating this electric machine.



**NOTE:**

In order to see the type and model of the machine, please see the specification plate. Usually found on the back of the machine. See example (Fig.1-1)

**HAFCO**  
PRODUCT SPECIFICATION

MODEL:	<input type="text"/>
CAPACITY:	<input type="text"/>
SER. NO:	<input type="text"/>
MFG DATE:	<input type="text"/>
WEIGHT:	<input type="text"/>
VOLTS:	<input type="text"/>
MOTOR Kw:	<input type="text"/>

[www.machineryhouse.com.au](http://www.machineryhouse.com.au)  
Made in China

Fig.1-1

**CONTENTS:****1. GENERAL MACHINE INFORMATION**

1.1 Specifications.....	4
1.2 Identification.....	5
1.3 Included Accessories.....	6

**2. IMPORTANT INFORMATION**

2.1 Safety Requirements.....	7
2.2 Chuck Safety.....	10

**3. SETUP**

3.1 Clean up.....	11
3.2 Site Preparation.....	11
3.3 Foundation Plan.....	12
3.4 Lifting.....	14
3.5 Levelling The Machine.....	15
3.6 Electrical Installation.....	15
3.7 Full Load Current.....	16

**4. COMPONENT INFORMATION**

4.1 Controls & Components.....	16
Control Panel.....	16
Headstock Controls.....	17
Apron.....	18
Tailstock.....	19
4.2 Offsetting the Tailstock.....	19
4.3 Aligning Tailstock To Spindle Centerline.....	20
4.4 Carriage & Slide Locks.....	21
4.5 Fixed And Traveling Steadies.....	21
4.6 Compound Rest & Toolpost.....	22
4.7 Setting The Cutting Tool With Spindle Centre.....	23
4.8 Four-Position Apron Stop.....	24
4.9 Gap Removal.....	24
4.10 Feeds And Threading.....	25
Apron Threading Controls.....	26
Thread Dial Indicator.....	26
4.11 End Gears.....	27

**5. TEST RUN & OPERATION**

5.1 Test Run.....	29
5.2 Chuck & Faceplate Mounting.....	30
5.3 Spindle Speeds.....	31
5.4 Taper Turning Attachment.....	32

**6. MAINTAINANCE**

6.1 Lubrication Type and Frequency.....	33
6.2 Lubrication Points.....	32
6.3 Feed Clutch Adjustment.....	37
6.4 Gib Adjustment.....	37
6.5 Brake And Micro Switch Adjustment.....	38
6.6 Adjusting The Lead Screw Backlash.....	38
6.7 Coolant Pump & Tank.....	38
6.8 Troubleshooting.....	39

**APPENDIX**

Spare Parts Section.....	42
Risk Assessment Sheets	

**1.1. SPECIFICATIONS**

<b>Model</b>	<b>CL-410</b>	<b>CL-460</b>
Swing Over Bed	410mm	460mm
Swing Over Cross Slide	220mm	274mm
Swing In Gap (dia)	640	690
Distance Between Centers	1000mm	1000 / 1500mm
Centre Height	205mm	230mm
Bed Width	300mm	300mm
Spindle Bore	58mm	80mm
Spindle Nose Size or Type	D1-6 Camlock	D1-6 Camlock
Spindle Steps / Speed Range	12 (25 - 2000rpm)	12 (25 - 1860rpm)
Headstock Spindle Taper	6MT	6MT
Tailstock Taper	4MT	4MT
Toolholder Size	25mm	25mm
Cross Slide Travel	285mm	285mm
Compound Slide Travel	128mm	128mm
Leadscrew	Metric 6mm Pitch	Metric 6mm Pitch
Cross Feed Range (X-Axis)	42 (0.014 - 0.784mm/rev)	42 (0.014 - 0.784mm/rev)
Longitudinal Feed Range (Z-Axis)	42 (0.31 - 1.7mm/rev)	42 (0.31 - 1.7mm/rev)
Metric Thread Steps & Pitch Range	41 (0.1 - 14mm)	47 (0.1 - 14mm)
Diametrical Pitches	50 (4-112D.P.)	50 (4-112D.P.)
Module Pitches	34 (0.1-7M.P.0)	34 (0.1-7M.P.0)
Imperial Thread Steps & TPI Range	60 (2 - 112tpi)	60 (2 - 112tpi)
Spindle Motor Power	5.5kW / 7.5hp	5.5kW / 7.5hp
Coolant Pump Motor Power	0.1kW(1/8HP)	0.1kW(1/8HP)
Voltage	415Volts	415Volts
Weight	1850kgs	1950 / 2150kgs
Machine Foot Print LxWxH):cm	230x110x160	230/280x110x160
Taper Turning Attachment	-	Fitted

**1.2 IDENTIFICATION**

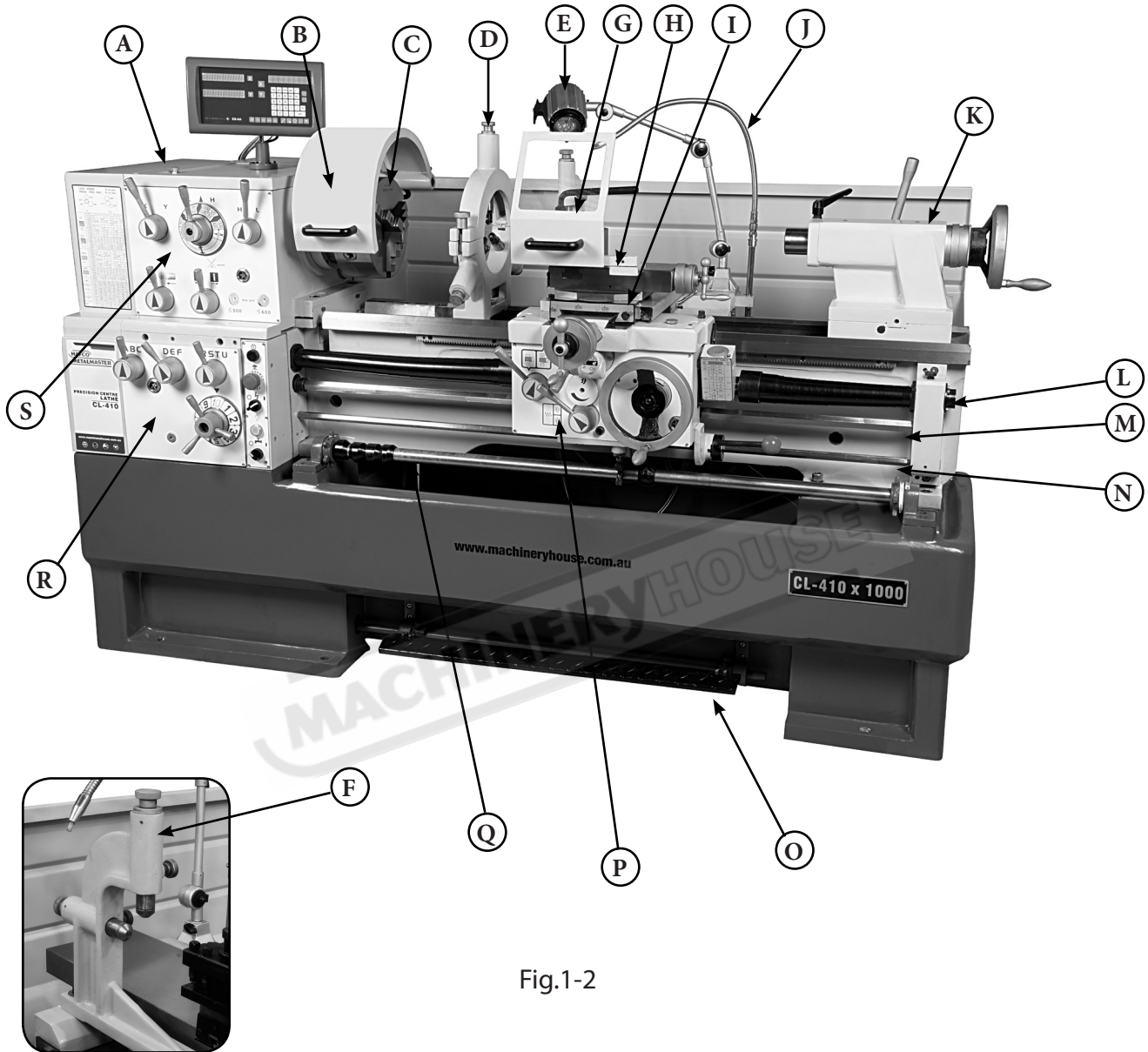

Fig.1-2

- |                  |                              |
|------------------|------------------------------|
| A. Headstock     | K. Tailstock                 |
| B. Chuck Guard   | L. Longitudinal Leadscrew    |
| C. 3-Jaw Chuck   | M. Feed Rod                  |
| D. Steady Rest   | N. Control Rod               |
| E. LED Work Lamp | O. Foot Brake                |
| F. Follow Rest   | P. Carriage                  |
| G. Tool Post     | Q. Eccentric Stop Ring Shaft |
| H. Compound Rest | R. Quick-Change Gearbox      |
| I. Cross Slide   | S. Headstock Controls        |
| J. Coolant Hose  |                              |

**1.3 INCLUDED ACCESSORIES**

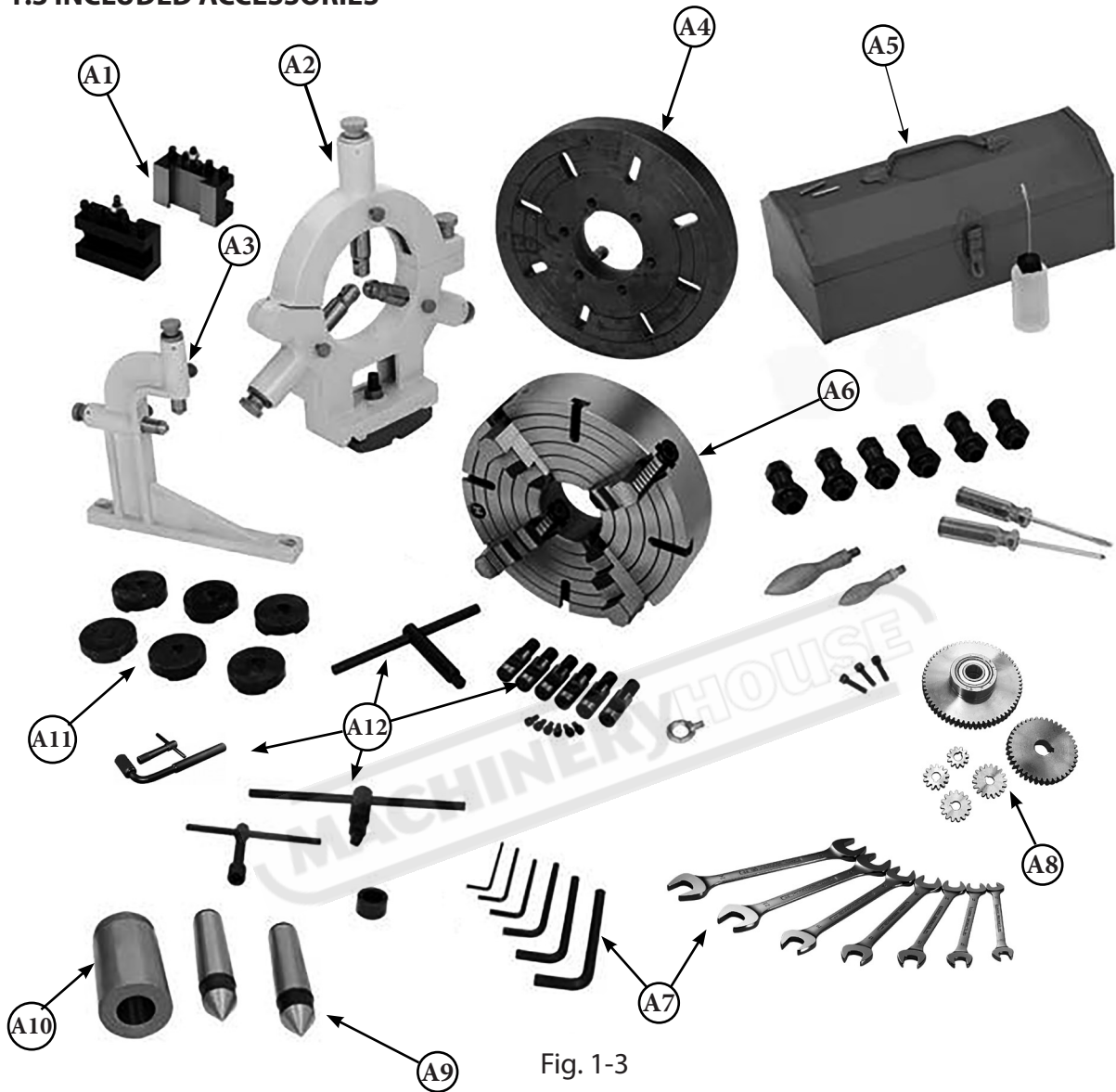

Fig. 1-3

A1	Toolholders	A7	Spanners and Hex Keys
A2	Fixed Steady	A8	Gears 64T and 40T
A3	Travelling Steady	A9	2 x 4MT Centers
A4	Faceplate	A10	6 x 4MT Sleeve
A5	Toolbox	A11	Cast Iron Mounting Pads
A6	4 Jaw Independent Chuck	A12	Chuck Keys and Camlocks

## 2. IMPORTANT INFORMATION

### 2.1 SAFETY REQUIREMENTS

DO NOT use this machine unless you have read this manual or have been instructed in the use of this machine in its safe use and operation



## WARNING

This manual provides safety instructions on the proper setup, operation, maintenance, and service of this machine. Save this manual, refer to it often, and use it to instruct other operators. Failure to read, understand and follow the instructions in this manual may result in fire or serious personal injury—including amputation, electrocution, or death.

The owner of this machine is solely responsible for its safe use. This responsibility includes, but is not limited to proper installation in a safe environment, personnel training and authorization to use, proper inspection and maintenance, manual availability and comprehension, application of safety devices, integrity, and the use of personal protective equipment.

The manufacturer will not be held liable for injury or property damage from negligence, improper training, machine modifications or misuse.



Safety glasses must be worn at all times in work areas. Earmuffs should be worn if the work area is noisy.



Sturdy footwear must be worn at all times in work areas.



Gloves should not be worn when using this machine. Rings and jewelery must not be worn.



Long and loose hair must be contained with a net or under a hat

**OWNER'S MANUAL.** Read and understand this owner's manual before using the machine.

**DISCONNECT POWER FIRST.** Always disconnect the machine from power supply before making adjustments, or servicing the machine.

This prevents any risk of injury from unintended startup or contact with live electrical components.

**TRAINED OPERATORS ONLY.** Operators that have not been trained have a higher risk of being seriously injured. Only allow trained or supervised people to use this machine. When the machine is not being used, disconnect the power, to the machine to prevent unauthorized use—especially around children. Make the workshop safe.

## 2.1 SAFETY REQUIREMENTS Cont.

**WEARING PROPER APPAREL** Do not wear clothing, apparel or jewelry that can become entangled in moving parts. Always tie back or cover long hair. Wear non-slip footwear to avoid accidental slips, which could cause loss of operating control.

**HEARING PROTECTION.** Always wear hearing protection when operating or observing loud machinery. Extended exposure to this noise without hearing protection can cause permanent hearing loss.

**REMOVE ADJUSTING TOOLS.** Tools left on machinery can become dangerous projectiles upon startup. Never leave chuck keys, wrenches, or any other tools on machine. Always verify removal before starting!

**USE CORRECT TOOL FOR THE JOB.** Only use this tool for its intended purpose. Do not force the machine or its attachments to do a job for which they were not designed. Never make unapproved modifications. Modifying the machine or using it differently than intended may result in malfunction or mechanical failure that can lead to personal injury or death!

**AWKWARD POSITIONS.** Keep proper footing and balance at all times when operating machine. Do not overreach! Avoid awkward hand positions that make operating control difficult. This could increase the risk of accidental injury

### **ELECTRICAL EQUIPMENT INJURY RISKS.**

There is a risk of being shocked, burned, or killed by touching live electrical components or improperly grounded machinery. To reduce this risk, only allow qualified service personnel to do electrical installation or repair work, and always disconnect power before accessing or exposing electrical equipment.

**FORCING MACHINERY.** Do not force the machine. It will do the job safer and better at the rate for which it was designed.

**NEVER STAND ON MACHINE.** Serious injury may occur if the machine is tipped or if the cutting tool is unintentionally contacted

**STABLE MACHINE.** Unexpected movement during operation greatly increases risk of injury or loss of control. Before starting, verify machine is stable and if using a mobile base it is locked in position.

**UNATTENDED OPERATION.** To reduce the risk of accidental injury, turn the machine OFF and ensure all moving parts have completely stopped before walking away. Never leave the machine running while unattended.

**MAINTAIN WITH CARE.** Follow all maintenance instructions and lubrication schedules to keep the machine in good working condition. A machine that is improperly maintained could malfunction, leading to serious personal injury or death.

**CHECK DAMAGED PARTS.** Regularly inspect the machine for any condition that may affect the safe operation. Immediately repair or replace damaged or parts that are incorrectly fitted before operating.

**MAINTAIN POWER CORDS.** When disconnecting the cord-connecting the machines from the power, hold and pull the plug—not the cord. Pulling the cord may damage the wires inside. Do not handle cord/plug with wet hands. Avoid cord damage by keeping it away from heated surfaces, high traffic areas, harsh chemicals, and wet/damp locations.

## 2.1 SAFETY REQUIREMENTS Cont.

**SPEED RATES.** Operating this lathe at the wrong speed could cause machine parts to break or the workpiece to come loose, which will result in dangerous projectiles that could cause severe impact injuries. Large or non-concentric workpieces must be turned at slow speeds. Always use the appropriate feed and speed rates

**CHUCK KEY SAFETY.** A chuck key left in the chuck can become a deadly projectile when the spindle is started. Always remove the chuck key after using it. Develop a habit of not taking your hand off of a chuck key unless it has been removed from the machine.

**SAFE CLEARANCES.** Workpieces that crash into other components on the lathe may throw dangerous projectiles in all directions, leading to impact injury and damaged equipment. Before starting the spindle, make sure the workpiece has adequate clearance by hand-rotating it through its entire range of motion. Also, check the tool and tool post, chuck, and saddle clearance.

**LONG WORKPIECE SAFETY.** Long workpiece can whip violently if not properly supported, causing serious impact injury and damage to the lathe. Reduce this risk by supporting any stock that extends from the chuck/headstock more than three times its own diameter. Always turn long stock at slow speeds.

**SECURING WORKPIECE.** An improperly secured workpiece can fly off the lathe spindle with deadly force, which can result in a severe impact injury. Make sure the workpiece is properly secured in the chuck or on the faceplate before starting the lathe.

**CRASHES.** Aggressively driving the cutting tool or other lathe components into the chuck may cause an explosion of metal fragments, which can result in severe impact injuries and major damage to the lathe. Reduce this risk by releasing automatic feeds after use, not leaving lathe unattended, and checking clearances before starting the lathe.

Make sure no part of the toolholder, compound rest, cross slide, or carriage will contact the chuck during operation.

**TOOL SELECTION.** Cutting with an incorrect or dull tool increases the risk of accidental injury due to the extra force required for the operation. Always select the right lathe tool for the job and make sure it is sharp.

A correct, sharp tool decreases strain and provides a better finish.

**GUARDS & COVERS.** Guards and covers reduce accidental contact with moving parts or flying debris. Make sure they are properly installed, undamaged, and working correctly.

**CHILDREN & BYSTANDERS.** Keep children and bystanders at a safe distance from the work area. Stop using machine if they become a distraction.

**CLEARING CHIPS.** Metal chips can easily cut bare skin—even through a piece of cloth. Avoid clearing chips by hand or with a rag. Use a brush or vacuum to clear metal chips.

**USE RECOMMENDED ACCESSORIES.** Consult this manual or the manufacturer for recommended accessories. Using improper accessories will increase the risk of serious injury.

## 2.2 CHUCK SAFETY INFORMATION



# WARNING

**CHUCKS.** Chucks are very heavy and difficult to grasp, which can lead to crushed fingers or hands if mishandled. Get assistance when handling chucks to reduce this risk. Protect your hands and the precision-ground ways by using a chuck cradle or piece of plywood over the ways of the lathe when servicing chucks. Use a lifting device when necessary.

**ENTANGLEMENT.** Entanglement with a rotating chuck can lead to death, amputation or serious injury. Always roll-up sleeves, tie back long hair and remove jewelry or loose clothing before operating

**CHUCK SPEED RATING.** Excessive spindle speeds greatly increase the risk of the workpiece or chuck being thrown from the machine with deadly force. Never use spindle speeds faster than the chuck RPM rating or the safe limits of your workpiece.

**USING CORRECT EQUIPMENT.** Many workpieces can only be safely turned in a lathe if additional support equipment, such as a tailstock or steady/follow rest, are used. In some cases a combination of steadies and tailstock can be used. If the operation is too hazardous to be completed with the lathe or existing equipment, the operator should be experienced enough to know when to use a different machine or find the safest way.

**TRAINED OPERATORS ONLY.** Using a chuck incorrectly can result in workpieces coming loose at high speeds and striking the operator or bystanders with deadly force. To reduce the risk of this hazard, read and understand this document and seek additional training from someone with experience in chuck use before proceeding.

**CHUCK CAPACITY.** Avoid exceeding the capacity of the chuck by clamping an oversized workpiece. If the workpiece is too large to safely clamp with the chuck, use a faceplate or a larger chuck if possible. otherwise, the workpiece could be thrown from the lathe during operation, and could result in serious impact injury or death.

**CLAMPING FORCE.** Inadequate clamping force can lead to the workpiece being thrown from the chuck and striking the operator or bystanders. Maximum clamping force is achieved when the chuck is properly maintained and lubricated, all jaws are fully engaged with the workpiece, and the maximum chuck clamping diameter is not exceeded.

**PROPER MAINTENANCE.** All chucks must be properly maintained and lubricated to achieve maximum clamping force and withstand the rigors of centrifugal force. To reduce the risk of a thrown workpiece, follow all maintenance intervals and instructions in this document.

**DISCONNECT POWER.** Serious entanglement or impact injuries could occur if the lathe is started while you are adjusting, servicing, or installing the chuck. Always disconnect the lathe from power before performing these procedures.

**STOPPING SPINDLE BY HAND.** Stopping the spindle by putting your hand on the workpiece or the chuck creates an extreme risk of entanglement, impact, crushing, friction, or cutting hazards. Never attempt to slow or stop the lathe spindle with your hand. Allow the spindle to come to a stop on its own or use the foot brake.

**3. SETUP**

**3.1 CLEAN - UP**

The unpainted surfaces of the machine have been coated with a waxy oil to protect them from corrosion during shipment. Remove the protective coating with a solvent cleaner or a citrus-based degreaser.

Optimum performance from your machine will be achieved when you clean all moving parts or sliding contact surfaces that are coated with rust prevented products.

Hafco advise to avoid chlorine based solvents, such as acetone or brake parts cleaner, as they will damage painted surfaces and strip metal should they come in contact. Always follow the manufacturer’s instructions when using any type of cleaning product.

**3.2 SITE PREPARATION**

When selecting the site for the machine, consider the largest size of workpiece that will be processed through the machine and provide enough space around the machine for operating the machine safely. Consideration should be given to the installation of auxiliary equipment. Leave enough space around the machine to open or remove doors/covers as required for the maintenance and service as described in this manual.

It is recommended that the machine is anchored to the floor to prevent tipping or shifting. It also reduces vibration that may occur during operation. See dimernsions for foundation bolts in Figures 3-3, 3-4

**OPTIONS FOR MOUNTING**

The machine is best mounted on a concrete slab.

Masonry anchors with bolts are the best way to anchor machinery, because the anchors sit flush with the floor surface, making it easy to unbolt and move the machine later, if needed. (Fig. 3-1)

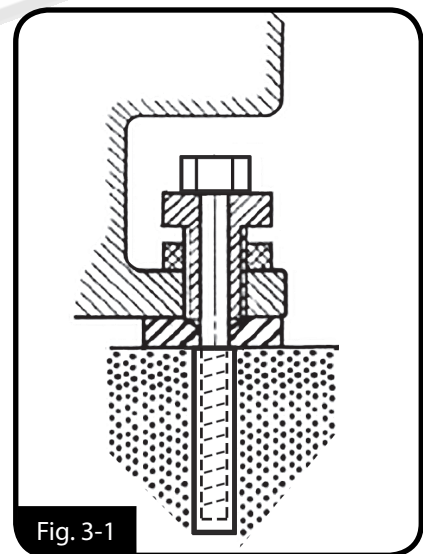

Fig. 3-1

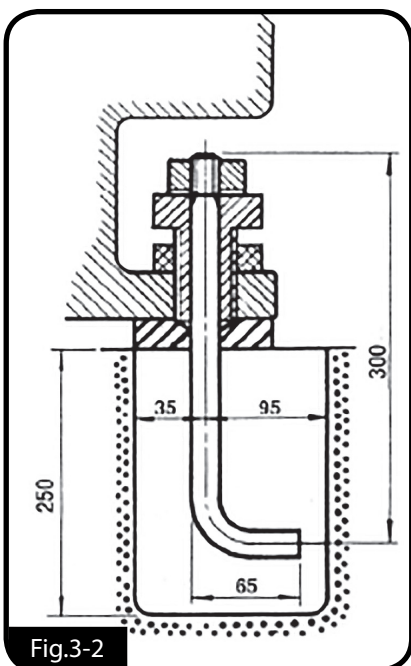

Fig.3-2

In some case a suitable foundation may not be available and a new one may need to be prepared. The foundation should be concrete approximately 200mm thick with pockets left clear for the hold down bolts.. The hold down bolts can be “L” shape as per the example in Fig. 3-2

**3.3 FOUNDATION PLAN**

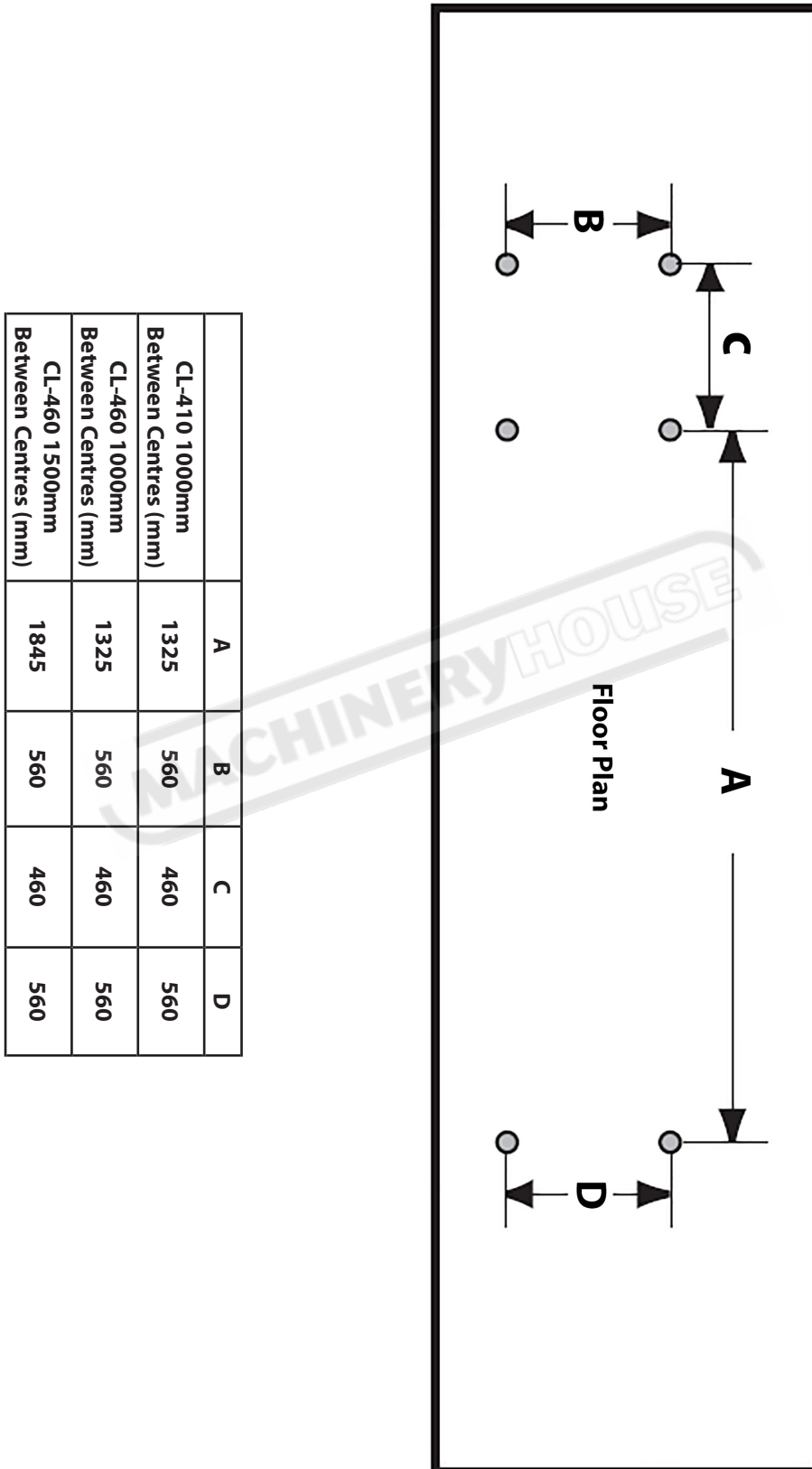

Fig. 3-3

**3.3 FOUNDATION PLAN Cont.**

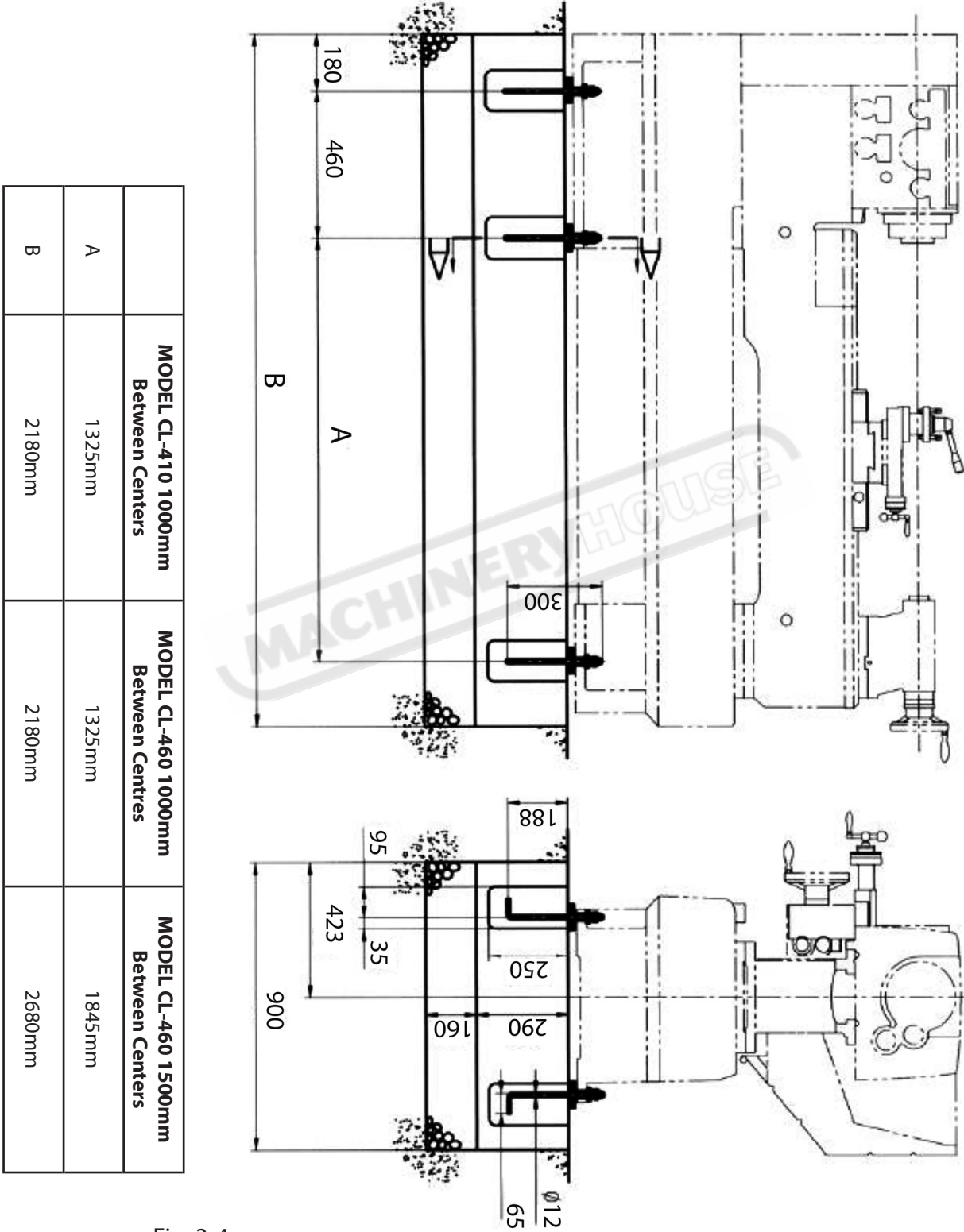

Fig. 3-4

### 3.4 LIFTING

Move the lathe to its prepared location while it is still attached to the shipping pallet. To balance the load for lifting, move the tailstock and carriage to the right end of the bedway, then lock them in place.

**Note:** Before attempting to move the carriage, make sure the carriage lock is loose, the half nut is disengaged, and the feed selection lever is disengaged. Refer to Page 18 to identify these controls. Prepare two round metal bars (approx. 830mm long x 40mm dia) and insert them into the preserved holes on the lathe bed. (See Fig. 3-5). Using web slings or chains place them around the bars and adjust the length until the lathe when it is raised is level. (see Fig. 3-6).

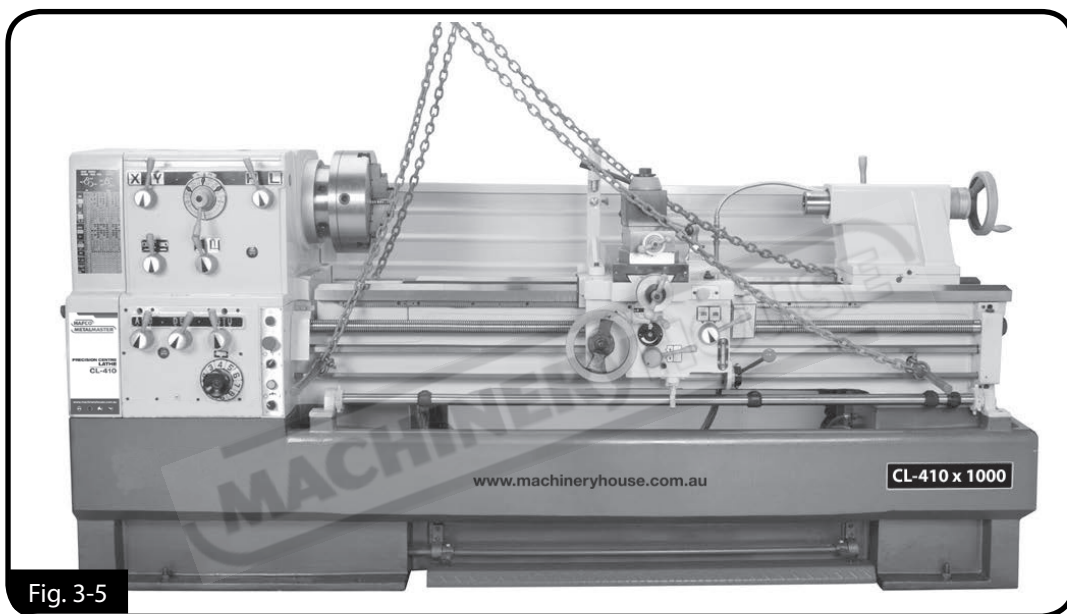

Fig. 3-5

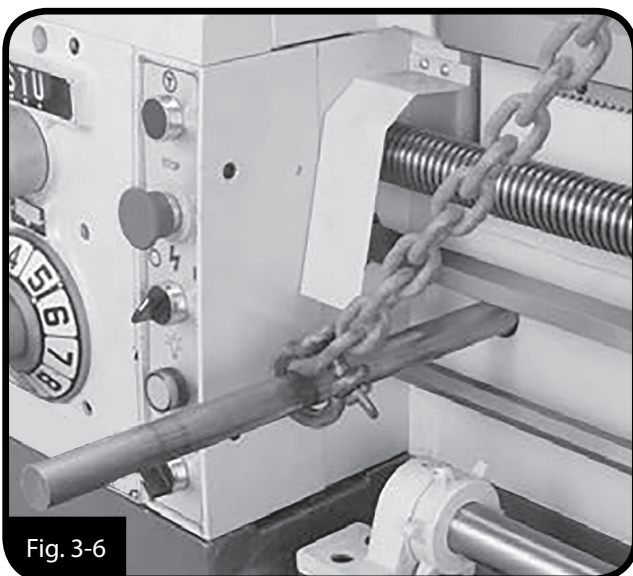

Fig. 3-6

**NOTE :**

Before lifting check that the slings or chains will not bend either the control shaft, lead screw, feed shaft, coolant hoses or electrical cables.

The slings or chains must be certified and suitable to handle the weight of the machine.

The lifting must be managed by an experienced persons with rigging and lifting qualifications.

**3.5 LEVELING**

This lathe can be placed on the included leveling screws and cast-iron pads (Figure 3-7), and the lathe should be secured to the floor. The lathe must be sitting flat at each mounting point, and the ways must be perfectly level. The bed cannot be twisted or bent. If the lathe is found to be misaligned, shim the lathe where it mounts to the floor, or adjust the leveling screws until the bed and ways are in alignment. A precision machinist’s level (Q205) should be used. Place the level on the bedways and on top of the cross slide for the best results (See Fig. 3-8)

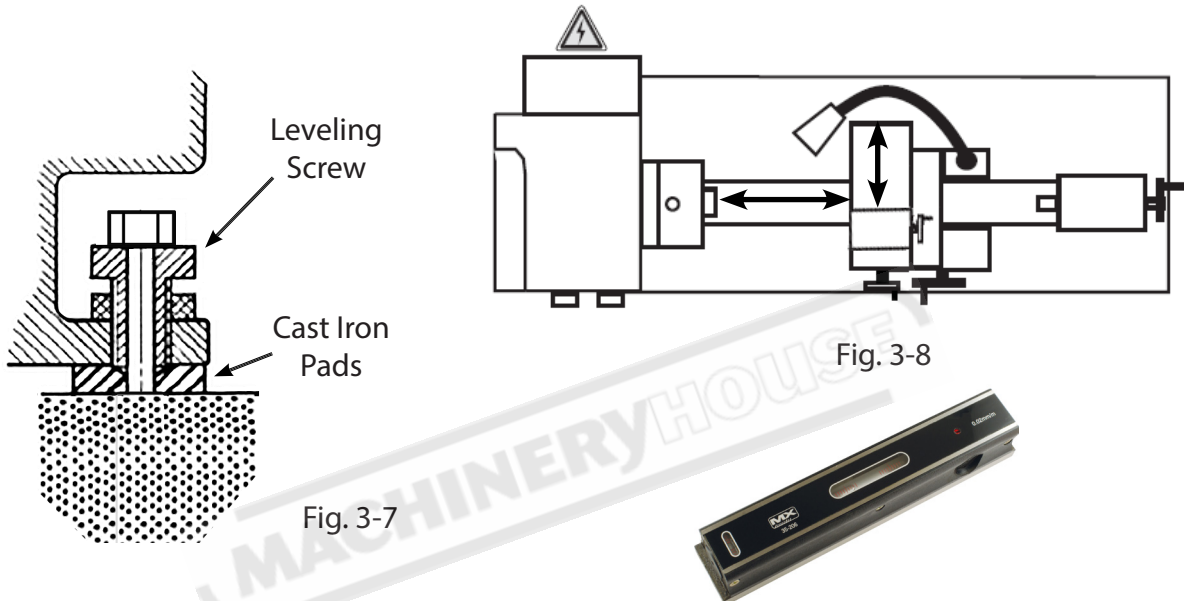

Fig. 3-7

Fig. 3-8



Order Code Q205

**3.6 ELECTRICAL INSTALLATION**

Place this machine near an existing power source. Make sure all power cords are protected from traffic, material handling, moisture, chemicals, or other hazards. Make sure there is access to a means of disconnecting the power source. The electrical circuit must meet the requirements for 415V. To minimize the risk of electrocution, fire, or equipment damage, these machines should be hard wired with installation work and electrical wiring done by a qualified electrician.

**NOTE :** The use of an extension cord is not recommended as it may decrease the life of electrical components on your machine.

**ELECTRICAL REQUIREMENTS**

<b>Nominal Voltage.....</b>	<b>415V</b>
<b>Cycle.....</b>	<b>50 Hz</b>
<b>Phase.....</b>	<b>Three Phase</b>
<b>Power Supply Circuit.....</b>	<b>20 Amps</b>
<b>Full Load Current.....</b>	<b>10.5 Amps</b>

(Full load current rating is also on the specification plate on the motor.)

### 3.7 FULL-LOAD CURRENT RATING

The full-load current rating is the amperage a machine draws at when running at 100% of the output power. Where machines have more than one motor, the full load current is the amperage drawn by the largest motor or a total of all the motors and electrical devices that might operate at one time during normal operations.

Full-Load Current Rating for these machine at 415V is 10.5 Amps

It should be noted that the full-load current is not the maximum amount of amps that the machine will draw. If the machine is overloaded, it will draw additional amps beyond the full-load rating and if the machine is overloaded for a long period of time, damage, overheating, or fire may be caused to the motor and circuitry.

This is especially true if connected to an undersized circuit or a long extension lead. To reduce the risk of these hazards, avoid overloading the machine during operation and make sure it is connected to a power supply circuit that meets the requirements.



## 4. COMPONENT INFORMATION

### 4.1 CONTROLS & COMPONENTS

#### CONTROL PANEL (Fig.4-1)

- 1. Jog Button:** Turns the spindle motor ON while being pressed and held.
- 2. Emergency Stop Button:** Stops all machine functions. Twist clockwise to reset.
- 3. Lathe Power Switch:** Turns power ON/OFF to the lathe so lathe operations can begin.
- 4. Power Light:** Indicates the lathe is energized when illuminated.
- 5. Coolant Pump Switch:** Turns coolant pump ON/OFF.

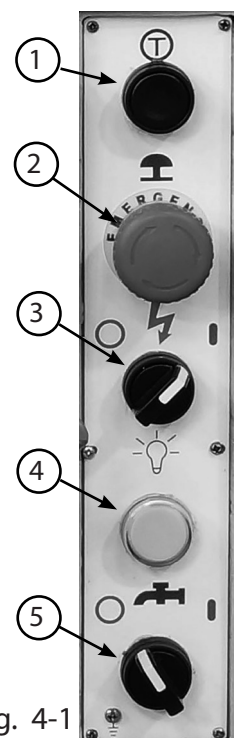

Fig. 4-1

**4.1 CONTROLS & COMPONENTS Cont.**

**HEADSTOCK CONTROLS  
(Fig.4-2)**

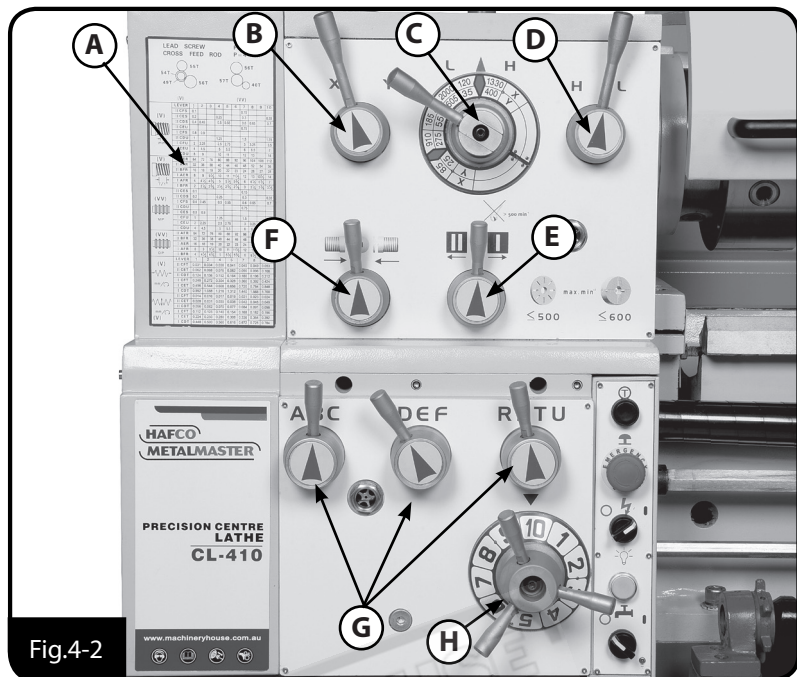

Fig.4-2

**A. Cutting Chart:** Used for shifting the lathe headstock and gearbox into the proper gear combinations for threading and feeding operations.

**B. Range Splitting Lever:** Used to select the final spindle speed from the set of high or low range speeds selected by the range lever.

**C. Spindle Speed Dial:** Positions the headstock gears in one of three speed modes. In each mode, there are four spindle speeds, with two speeds in low range, and two speeds in high range.

**D. Range Lever:** Used to select a set of high or low range spindle speeds from one of the three spindle speed modes shown on the spindle speed dial.

**E. Gearbox Hi/Lo Lever:** This lever puts the gearbox in high or low range and has no effect on spindle RPM. I is Hi range, II is low range.

**F. Leadscrew/Feedrod Direction Lever:** Changes the rotation direction of the leadscrew or feedrod so the apron or cross feed will move in the opposite direction.

**G. Quick Change Gearbox Levers:** Moves the gearbox gears into particular ratios, which then turn the leadscrew and feedrod for threading and power feed operations.

**H. Leadscrew/Feedrod Direction Lever:** Changes the rotation direction of the leadscrew or feedrod so the apron or cross feed will move in the opposite direction.

**4.1 CONTROLS & COMPONENTS Cont.**

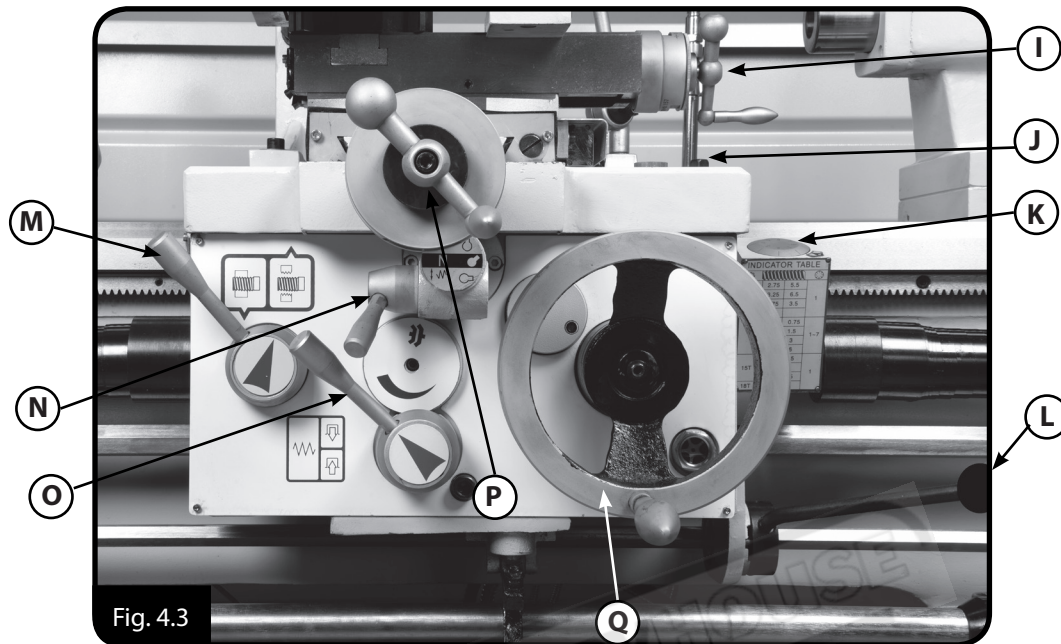

Fig. 4.3

**APRON (Fig. 4.3)**

**I. Compound Slide Handwheel:** Moves the tool toward and away from the workpiece at the preset angle of the compound slide.

**J. Carriage Lock:** Secures the carriage in place for greater rigidity when it should not move.

**K. Thread Dial:** Indicates when to engage the half nut during threading operations.

**L. Spindle Lever:** Starts, stops and reverses direction of spindle rotation.

**M. Half Nut Lever:** Engages/disengages the half nut for threading operations.

**N. Feed Selection Lever:** Selects the carriage or cross slide for power feed.

**O. Feed Clutch Lever:** Engages the feed mechanical for the item selected.

**P. Cross Slide Handwheel:** Moves the cross slide toward and away from the workpiece.

**Q. Carriage Handwheel:** Moves the carriage along the bed.

**4.1 CONTROLS & COMPONENTS Cont.**

**TAILSTOCK (Fig.4.4)**

**R. Quill Handwheel:** Moves the quill toward or away from the spindle.

**S. Graduated Scale:** Indicates quill movement in increments of 0.02mm or 0.001" graduations.

**T. Tailstock Lock Lever:** Secures the tailstock in position along the bedway.

**U. Quill Lock Lever:** Secures the quill in position.

**V. Quill:** Moves toward and away from the spindle and holds centers and tooling.

**W. Tailstock Offset Screws:** Adjusts the tailstock offset left or right from the spindle centerline (1 of 2).

**X. Offset Scale:** Indicates the relative distance of tailstock offset from the spindle centerline. (Fig. 4.5)

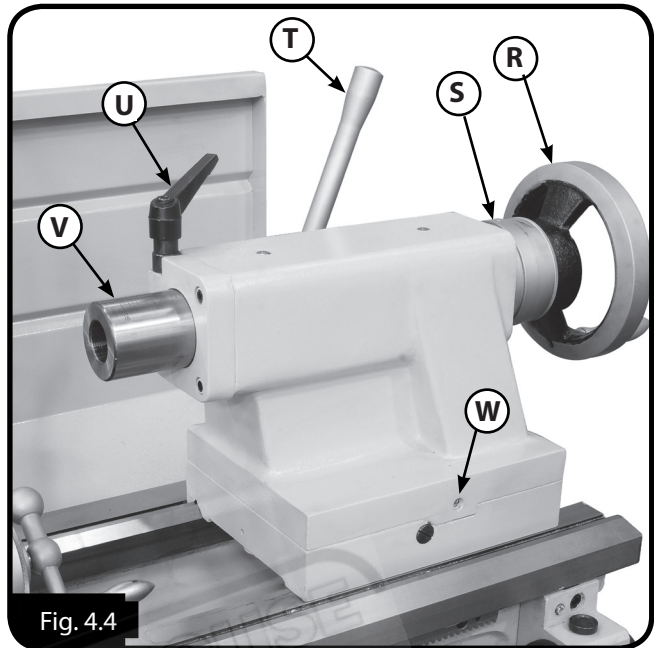

Fig. 4.4

**4.2 OFFSETTING THE TAILSTOCK**

The tailstock is typically used to support long workpieces by means of a live or dead center. It can also be used to hold a drill or chuck to drill holes in the center of the end of a part. Custom arbors and tapers can also be cut on your lathe by using the offset tailstock adjustment screws (W in Fig. 4.4)

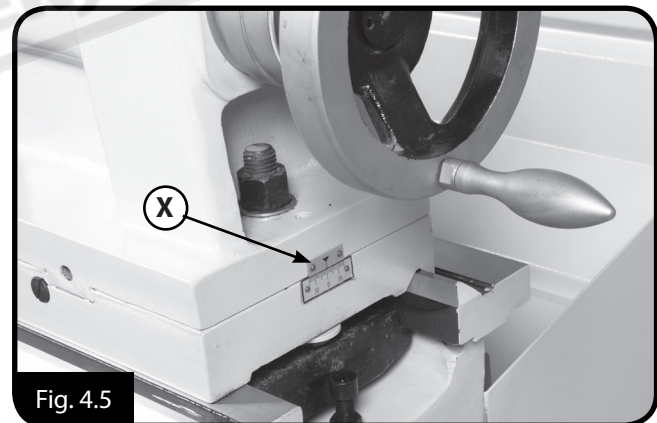

Fig. 4.5

The tailstock can be offset from the spindle centerline for turning tapers. Move the tailstock top casting toward the front of the lathe to machine a taper at the tailstock end. Conversely, move the tailstock top casting toward the back of the lathe to machine a taper at the spindle end

**Note:** The marks on the indicator on the end of the tailstock (Fig. 4.5) are only a guide. For a precise offset, use a dial indicator to check while adjusting the screws that are located on both sides of the tailstock. (W in Fig. 4.4)

### 4.3 ALIGNING TAILSTOCK TO SPINDLE CENTERLINE

This is an essential adjustment that should be checked or performed each time the tailstock is used to turn concentric workpieces between centers or immediately after offsetting the tailstock when turning a taper. If the tailstock is not aligned with the spindle centerline when it is supposed to be, turning results will not be parallel along the length of the workpiece.

#### Steps to align the tailstock to the spindle centerline:

1. Center drill both ends of one piece of round bar, then set it aside for use in a later step 4

2. Use the other piece of round stock to make a dead center, and turn it to a 60° point, as illustrated in the Fig. 4.6

**NOTE :** Do not remove machined centre from the chuck. The point of the center will remain true to the spindle centerline

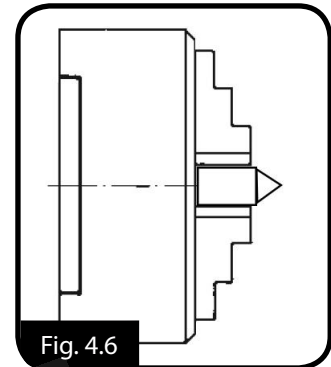

Fig. 4.6



Fig. 4.7

3. Install a center in the tailstock.

4. Attach a lathe dog to the test piece of round stock from Step 1, then mount it between the centers as shown in Fig. 4.7

5. Turn 1mm off the stock diameter.

6. Mount a test or dial indicator so that the plunger is on the tailstock quill and set the dial to "0" (Fig. 4.8)

7. Use a micrometer to measure both ends of the workpiece. If the test stock is larger at the tailstock end, then adjust the tailstock toward the front of the lathe 1/2 the distance of the difference. ( See Fig. 4.4 for adjustment screws)

8. Repeat the steps until the round bar is turned parallel.

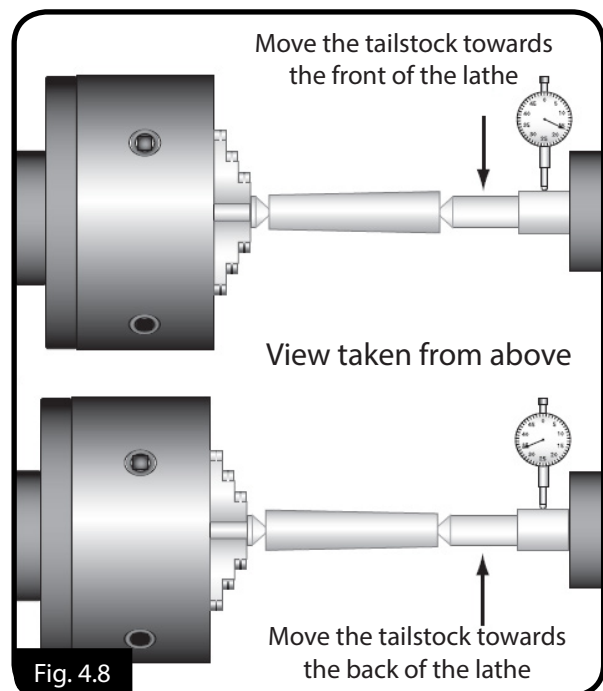

Fig. 4.8

#### 4.4 CARRIAGE & SLIDE LOCKS

The compound rest, and carriage are fitted with locks that can be tightened to increase rigidity when taking heavy turning cuts.

See Fig. 4.9 for the locations of the locks for each device.

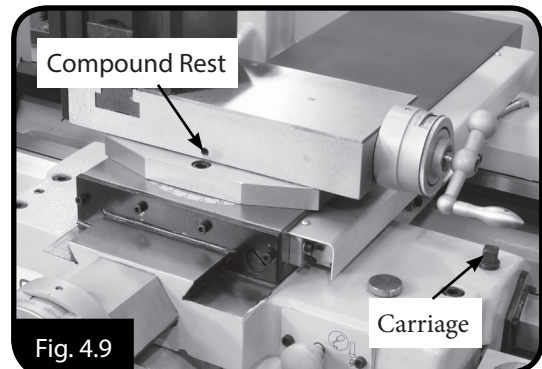

Fig. 4.9

#### 4.5 FIXED AND TRAVELING STEADIES

##### FIXED STEADY REST

The fixed steady rest supports long, small diameter shafts and can be mounted anywhere along the length of the bedway. Components are shown in Figure 4.10.

To install, thoroughly clean all mating surfaces, then place the fixed steady rest base on the bedways so the triangular notch fits over the bedway prism. Position the fixed steady rest with the base clamp where required to properly support the workpiece, then tighten the hex clamp nut. Undo the clamp knob and open the steady rest. Use the finger adjustment knobs to position the bottom two centre rollers against the workpiece. then close the steady rest making sure that the top centre roller does not touch the workpiece.

Close the steady rest, then use the finger adjustment knobs to adjust all three centre rollers to just touch the workpiece without causing any deflection.

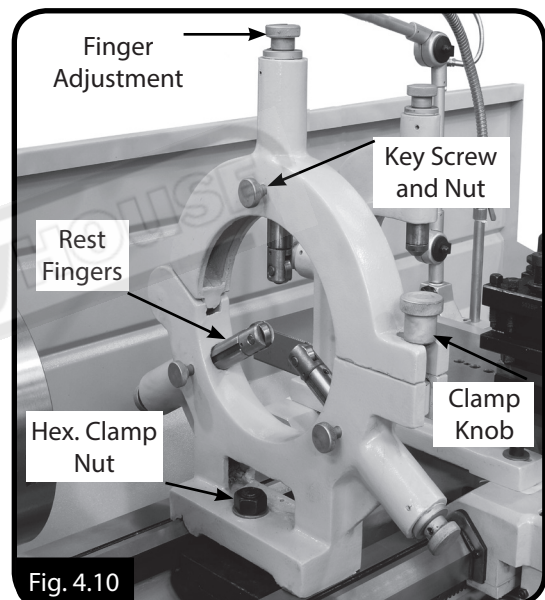

Fig. 4.10

##### TRAVELLING STEADY REST

The travelling rest is used when turning long, slender parts to prevent the workpiece from being deflected by the pressure of the cutting tool. It mounts to the saddle with two cap screws (see Fig. 4.11 ).

Adjustment of the follow rest fingers is done in the same manner as those for the fixed steady rest.

**NOTE:** To reduce the effects of friction, lubricate the fingers with way oil during operation.

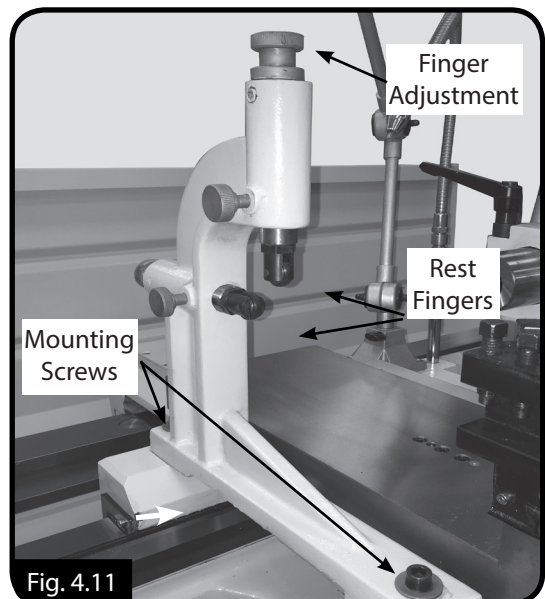

Fig. 4.11

## 4.6 COMPOUND REST & TOOLPOST

### COMPOUND REST

The compound rest provides a smaller amount of movement along its axis via another feed-screw. The compound rest axis can be adjusted independently of the carriage or cross-slide. It is used for turning short tapers, to control depth of cut when screwcutting or precision facing, or to obtain finer feeds (under manual control) than the feed shaft permits.

#### To set the compound rest at a certain angle:

1. Loosen the two hex screws at the base of the compound rest. (One at the front and one at the back of the compound slide.) (Fig 4.12).
2. Rotate the compound rest to the desired angle, as indicated by the scale at the base, then retighten the two hex screws.

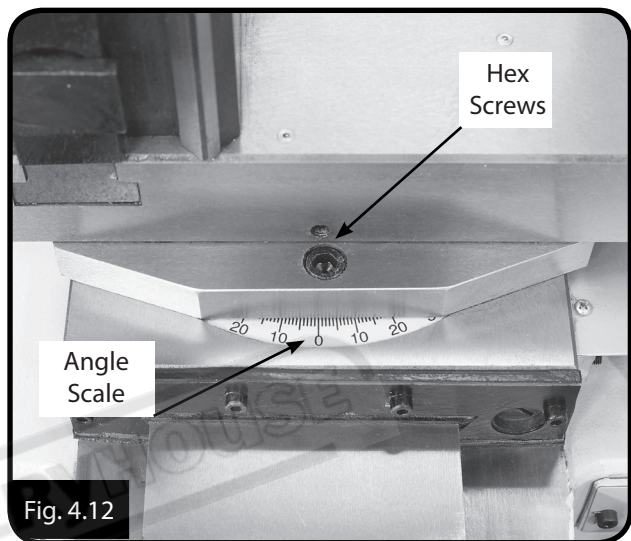

Fig. 4.12

### TOOL POST

The tool bit is mounted in the toolpost which is a quick-change style. The advantage of a quick change set-up is to allow an unlimited number of tools to be used (up to the number of holders available) rather than being limited to four tools with the four-sided type. Interchangeable tool holders allow all tools to be preset to the center height which remains constant, even if the holder is removed and replaced on the machine. (Fig. 4.13)

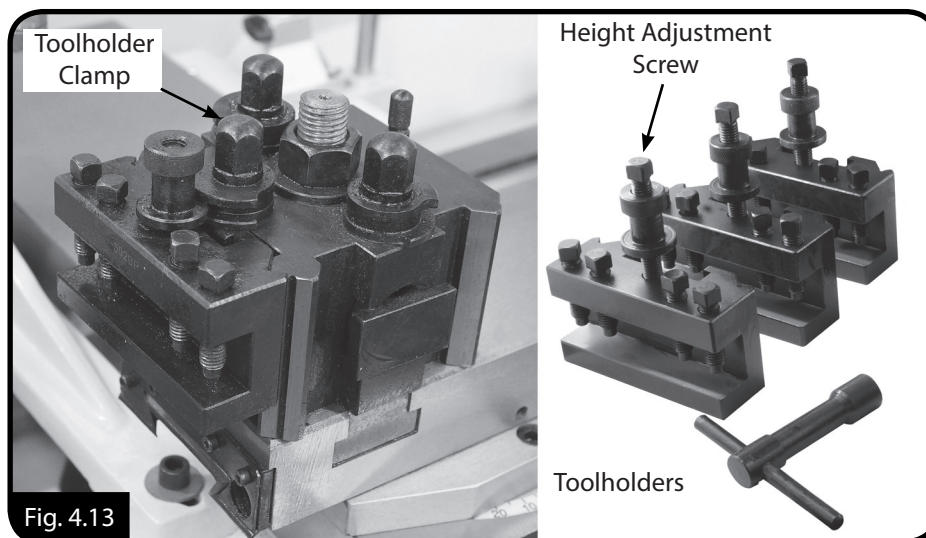

Fig. 4.13

Extra Holders  
available  
Order Code  
L294A

**4.7 SETTING THE CUTTING TOOL WITH SPINDLE CENTERLINE**

The tip of the cutting tool should be set up so that it is in line with the centerline of the spindle, as illustrated in Fig 4.14 . The cutting tool can be raised by placing steel shims underneath it. The shims should be as long and as wide as the cutting tool to properly support it. If fitted with a quick change toolpost height adjustment can be easily set with the height adjusting screw.

There are a number of ways to check that the cutting tool is on the centre line of the spindle.

**Below are two common methods:**

- Move the tailstock center over the cross slide and use a fine ruler to measure the distance from the surface of the cross slide to the tip of the center. Adjust the cutting tool height so it is the same distance above the cross slide as the tailstock center.

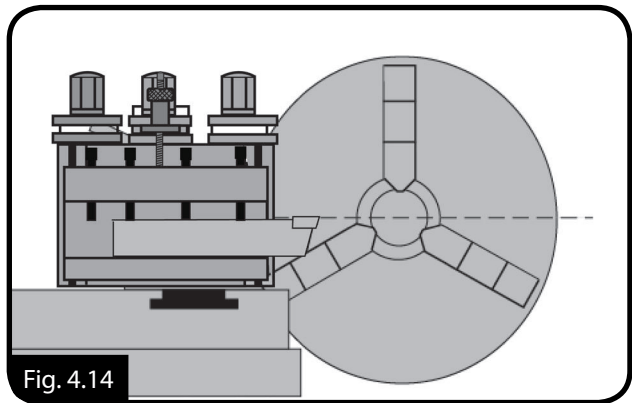

- Align the tip of the cutting tool with a tailstock center, as described in the following procedure.

1. Mount the cutting tool and secure the post so the tool faces the tailstock.
2. Install a center in the tailstock, and position the tip near the cutting tool.
3. Lock the tailstock and quill in place.
4. Adjust the height of the cutting tool tip to meet the center tip, as shown. (Fig.4.15)

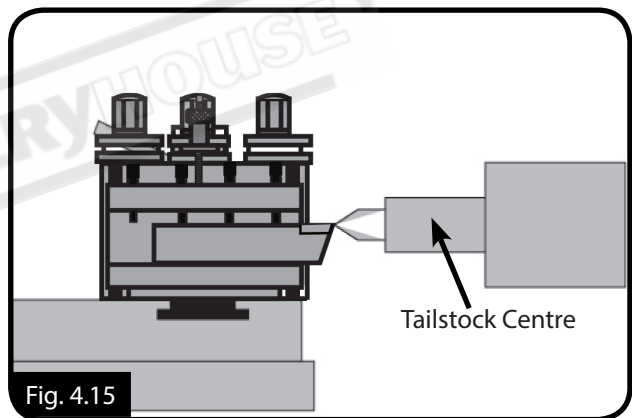

**To set the height**

Place the toolholder with the cutting tool attached onto the block and rotate "A" until the toolholder can slightly move up and down. Loosen the locking screw "B" in Fig 4.16. Adjust the height stop "C" until the tool tip is in line with the centre line. Tighten "B" lock screw then tighten the toolholder to the block with screw "A". Check the centre height of the tool tip and if not correct repeat the steps until on the centre line. Remove the toolholder by releasing "A" screw and replace. Check again the centre height.

**NOTE:** The locking screw "B" can be supplied as a set screw or a grub screw.

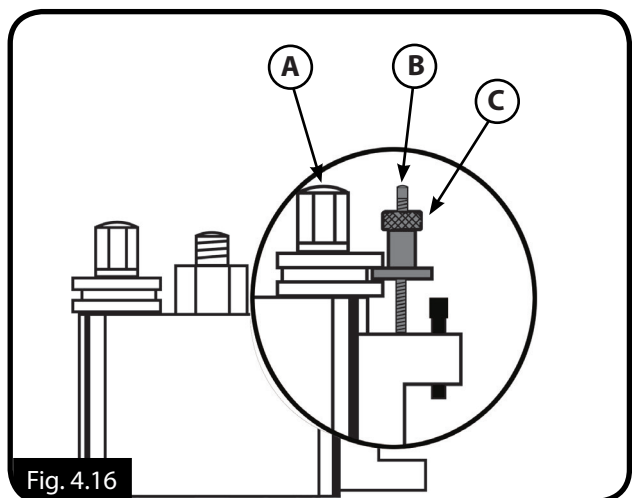

#### 4.8 FOUR-POSITION APRON STOP

The four-position apron stop is used for disengaging the apron automatically at a total of four different apron positions. The eccentrics rings ("C" in Fig.4.17) can be tightened in place on the shaft at different positions, and the shaft rotated with each stop corresponding with a number on the dial.

When the shaft is turned to the stop selected the stop is selected. When the apron reaches that point, the top of the stop eccentric will depress the clutch release lever ("D" in Fig. 4.18) and disengage the feed on the apron, thus stopping the apron.

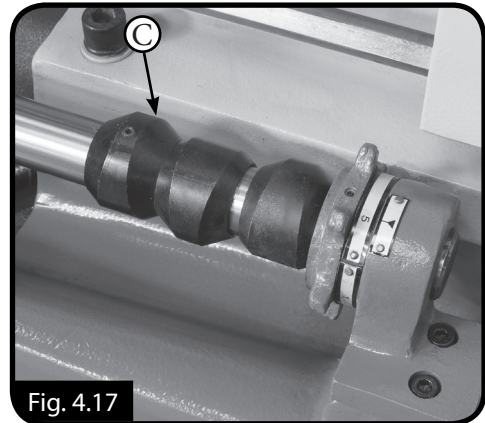

Fig. 4.17

#### 4.9 GAP REMOVAL

This lathe is fitted with a gap section below the spindle that can be removed for machining large diameter parts. The gap is installed, during lathe assembly at the factory and then finished ground for precise fit and alignment. Once the gap has been removed replacing the gap to the original position will be very difficult. Reinstating the gap to the original factory alignment is nearly impossible. For this reason Hafco do not recommend removing the gap unless absolutely necessary and then recommend to then leave the gap out.

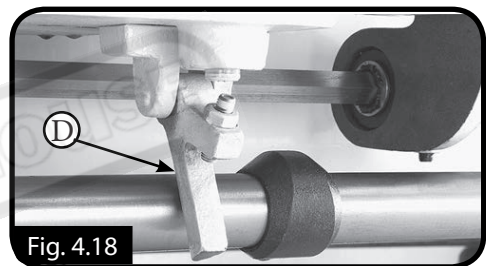

Fig. 4.18

##### To remove the gap

1. Remove the four cap screws from the bottom of the gap and two from the ends of the ways ("E" in Fig. 4.19).
2. Remove the set screw plug, and assemble an M6 x 30 cap screw, 6mm flat washer, and the gap pin puller hub ("F" in Fig. 4.19)
3. Thread the cap screw into the threaded hole and tighten until the pin is pulled free of the gap and bed.
4. Repeat on the remaining pin.
5. Tap the outside of the gap with a dead blow hammer to loosen, and remove the gap section

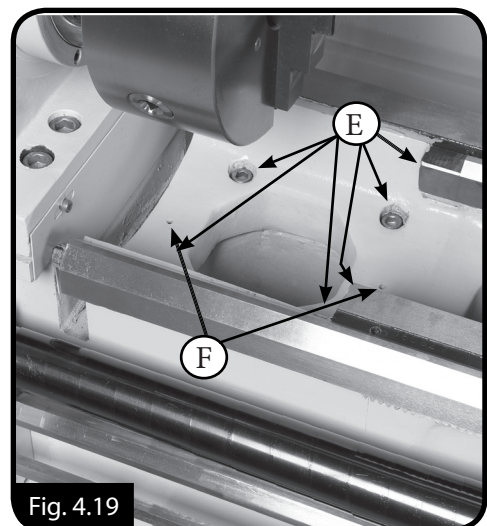

Fig. 4.19



**APRON THREADING CONTROLS**

The half nut lever engages the carriage with the leadscrew, which moves the carriage and cutting tool along the length of the workpiece for threading operations (see Fig. 4.22).

**NOTE :** Make sure the feed selection lever is in the disengaged (middle) position before attempting to engage the half nut.

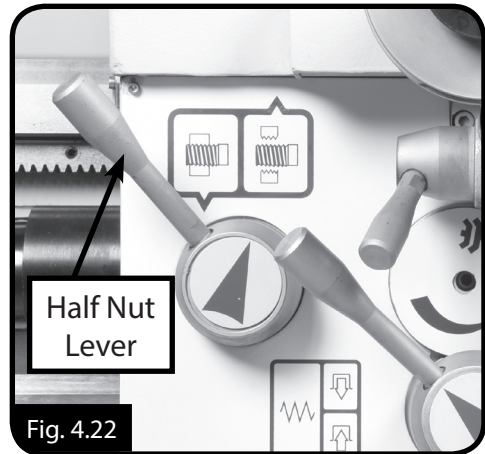

Fig. 4.22

**THREAD DIAL INDICATOR**

It is advised to use the slowest speed when thread cutting. The lathe is fitted with a Thread Dial Indicator with numbers on the thread dial indicator face which are used to show when to engage the half nut during threading. Before commencing check with the thread dial chart what number should be used. (Fig.4.23)

**Note!** When cutting threads sometimes the pitch of the leadscrew does not allow for the half nuts to be disengaged so the tool will need to be cleared and the machine will need to be reversed.

1. Loosen the cap screw on the thread dial and pivot the gear teeth so they mesh with the leadscrew threads, then re-tighten the cap screw. (see Fig. 4.24),
2. When the first cutting pass is complete, disengage the carriage from the leadscrew using the half nut lever. Return the carriage for the next pass and re-engage the half nut using the same thread dial setting to resume the cut in the previous pass.

**NOTE :** If the thread required is not on the chart then the method below is used.

1. Before taking the first cut set the crossslide dial to "0"
2. Engage the half nuts and take the first cut. When the tool reaches the end of the cut wind the tool away from the job and stop the machine. **DO NOT Disengage The Halfnuts.**
3. Reverse the spindle and return the carriage for the next pass and wind in the crossslide to "0" and add a small amount for the cut.

**NOTE :** Always use small cuts for the best results



INDICATOR TABLE			
			
11T	2.75	5.5	1
13T	3.25	6.5	
14T	1.75	3.5	1-7
	7		
	0.5	0.75	
	1	1.5	
	2	3	
	4	6	
15T	1.25	2.5	
	5		
	2.25	4.5	
18T	6.75		

Fig. 4.23

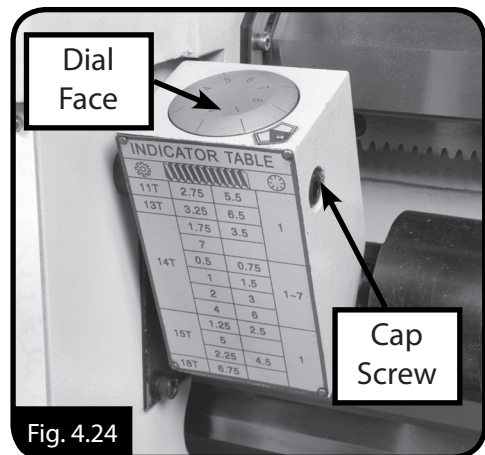

Fig. 4.24

### 4.11 END GEARS

The end gears are used to setup for power feed, and inch, or metric threading operations. See Fig. 4.25 to identify the upper gear, middle 54T/49T change gears, and the lower gear. Details on which gears to use is found in the feed and threading charts on the headstock.

The lathe may need to have the centre gears changed to cut other pitch threads, and may require the centre 54 tooth gear to be replaced with the 57 tooth gear. The following covers this process.

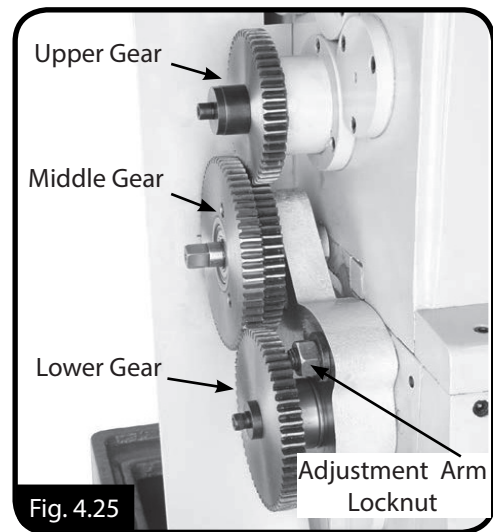

Fig. 4.25

### END-GEAR CONFIGURATION

To configure the end gears, first

1. Locate the chart on the headstock that has the thread or feed option that is required.
2. **DISCONNECT LATHE FROM POWER!**
3. Remove the headstock end gear cover.
4. Using a 14mm wrench, remove the center spindle and gear assembly (Fig. 4.26).
5. Using retaining ring pliers, remove the circlip from the spindle (Fig. 4.26).
5. With the circlip removed, Use a press to remove the spindle.

**Note:** A press and a collar that will support the inner bearing race should be used when removing the spindle from the gear so as not to damage the ball bearings.

6. Remove the three M6-1 x 25 cap screws that hold the two gears together.
7. Carefully, using two flat tip screwdrivers inserted between the gears at opposing sides, ease the 54-tooth gear off of the shoulder. Do not use a hammer to separate the gears.
9. Use the 6mm hex wrench and remove the lower and top spindle cap screw, shoulder washer, to change the bottom and top gears. (Fig. 4.27)

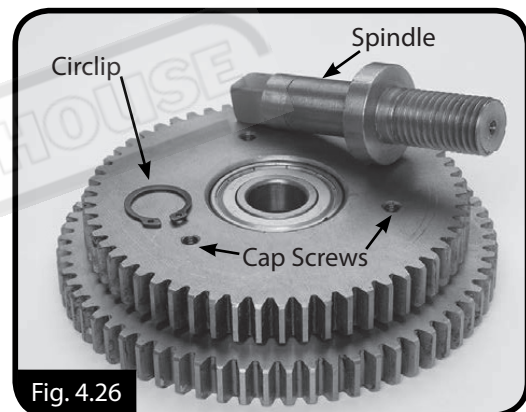

Fig. 4.26

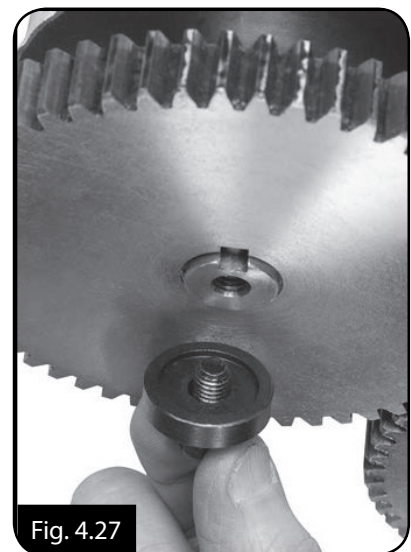

Fig. 4.27

**END-GEAR CONFIGURATION Cont.**

**NOTE:** In some casers a spacer may need to be used on the bottom shaft to make the bottom gear mesh with the outside gear of the centre gears.

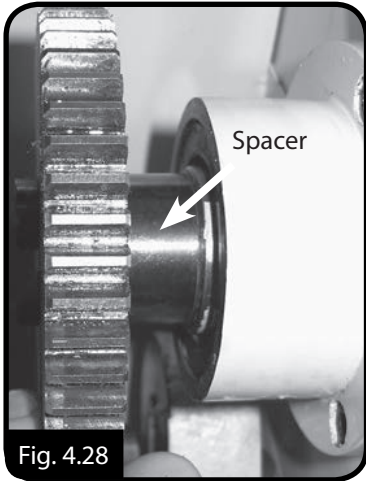

Fig. 4.28

10. If required slide the spacer onto the spindle, (Fig. 4.28) then slide the gear on the shaft. If the spacer is not required then place the gear on the shaft so that the shoulder is then placed against the bearing (Fig. 4.29).
11. Move the center gear and adjustment arm assembly, so they mesh with the top and bottom gear then tighten the spindle and adjustment arm lock nut so all gears mesh and have approximately 0.038 to 0.102mm of backlash.

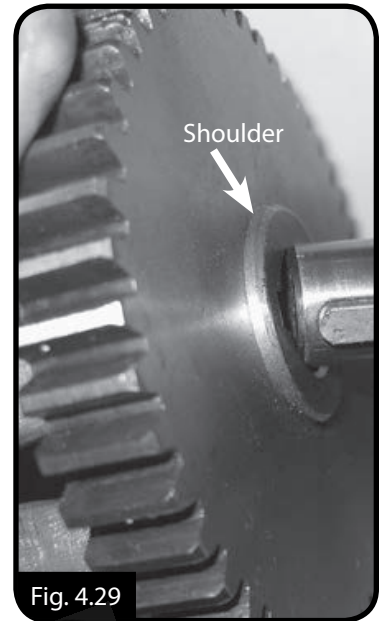

Fig. 4.29

12. Rotate the gears by hand to make sure that no binding occurs, and then cover the gear teeth with general purpose automotive grease.
13. When the change is finished, make sure the gear arrangement matches the configuration shown on the chart
14. Close the end cover and refer to the Threading Chart for how to shift the lathe to the appropriate feed or thread pitch. (Fig. 4.30)

LEAD SCREW P=6 mm  
CROSS FEED ROD P=4 mm

	(V)	1	2	3	4	5	6	7	8	9	10
II CFS	0.1								0.15		
II CES	0.2			0.25				0.3			0.35
II CDS	0.4	0.45		0.5	0.55			0.6	0.65		0.7
II CEU									0.75		
I CFS	0.8	0.9									
II CDU	1			1.25				1.5			1.75
I CFU	2	2.25		2.5	2.75			3	3.25		3.5
I CEU	4	4.5		5	5.5			6	6.5		7
I CDU	8	9		10	11			12	13		14
II AER	64	72	76	80	88	92	96	104	108	112	
II AFR	32	36	38	40	44	46	48	52	54	56	
II BFR	16	18	19	20	22	23	24	26	27	28	
I AER	8	9	9 1/2	10	11	11 1/2	12	13	13 1/2	14	
I AFR	4	4 1/2	4 3/4	5	5 1/2	5 3/4	6	6 1/2	6 3/4	7	
I BFR	2	2 1/4	2 3/8	2 1/2	2 3/4	2 7/8	3	3 1/4	3 3/8	3 1/2	
II CES	0.1								0.15		
II CDS	0.2			0.25				0.3			0.35
I CFS	0.4	0.45		0.5	0.55			0.6	0.65		0.7
II CEU									0.75		
I CFS	0.8	0.9									
II CDU	1			1.25				1.5			1.75
I CEU	2	2.25		2.5	2.75			3	3.25		3.5
I CDU	4	4.5		5	5.5			6	6.5		7
II AFR	64	72	76	80	88	92	96	104	108	112	
II BFR	32	36	38	40	44	46	48	52	54	56	
I AER	16	18	19	20	22	23	24	26	27	28	
I AFR	8	9	9 1/2	10	11	11 1/2	12	13	13 1/2	14	
I BFR	4	4 1/2	4 3/4	5	5 1/2	5 3/4	6	6 1/2	6 3/4	7	

Fig. 4.30

**5. TEST RUN & OPERATION**

**5.1 TEST RUN**

Once the assembly and setup of the machine is complete, test run your machine to make sure it runs properly and is ready for regular operation. The test run consists of verifying the following:

1. The motor powers up and runs correctly, and in the right direction.
2. The emergency STOP/RESET button safety feature works correctly.

If, during the test run, you cannot easily locate the source of an unusual noise or vibration, stop the machine immediately,

Read and understand the safety instructions at the beginning of this manual. Take all required safety precautions, and make sure all previous preparation steps have been followed and completed. Clear away all tools and objects used during assembly, lubrication, and preparation. Make sure that the chuck and jaws, if installed, will swing clear, and are secure (refer to Chuck Installation on Page 30)



**WARNING**

Check the headstock, quick-change gearbox, and apron oil reservoirs to ensure they have the proper amount of oil in them before the lathe can be operated. Damage can be caused to the bearings and gears from running the lathe without oil in the reservoirs and will not be covered under warranty. Refer to the Lubrication section, (see Page 34 )

**a.** To ensure the carriage components do not unexpectedly move during the following steps, disengage the half nut lever and feed selection lever (see Fig. 5.1).

**b.** Make sure the spindle lever is in the middle OFF position (Fig. 5.1)

**c.** Rotate the emergency STOP/RESET button clockwise so it pops out. The power lamp on the control panel should illuminate. Make sure the chuck guard is closed.

**d.** Set the spindle speed levers so the speed is at 120 RPM

**e.** Move the spindle lever (Fig. 5.1) down to start the spindle. The top of the chuck should turn down and toward the front of the lathe.

**f.** Push the emergency STOP/RESET button to turn the lathe OFF, then, without resetting the RESET button, try to restart spindle rotation, as instructed in the previous step. The spindle should not start.

**g.** Move the spindle lever to the OFF (middle) position, and reset the RESET button by twisting it clockwise until it pops out and then restart the lathe by moving the spindle lever down. The test run is now completed

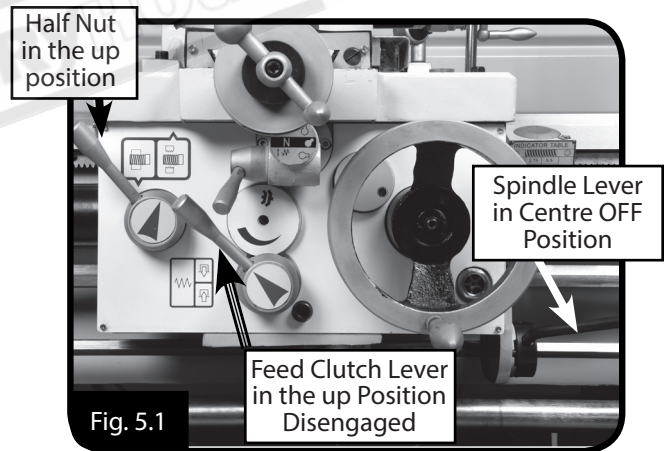

**5.2 CHUCK & FACEPLATE MOUNTING**

This lathe is equipped with a D1- 6 Camlock spindle nose. This type of spindle uses cams that are adjusted with a chuck key to securely mount a chuck or faceplate with repeatable precision and ease.

Because chucks are heavy and often awkward to hold, some kind of lifting, support, or protective device should be used during installation or removal. (Fig. 5.2)

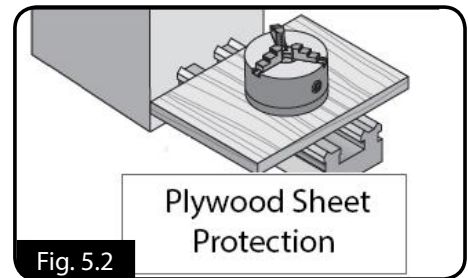

Fig. 5.2

To ensure that the work is accurate, it is extremely important to make sure the spindle nose and chuck mating surfaces and tapers are clean. Even a small amount of lint or dirt can affect the accuracy.

The chuck is properly installed when all camlocks are tight, the spindle and chuck tapers firmly lock together, and the back of the chuck is firmly seated against the face of the spindle all the way around without any gaps.

**Mounting The Chuck**

Clean and lightly oil the camlock studs, then thoroughly clean the mating surfaces of the spindle and chuck. Install the chuck by inserting the camlock studs straight into the spindle cam holes.

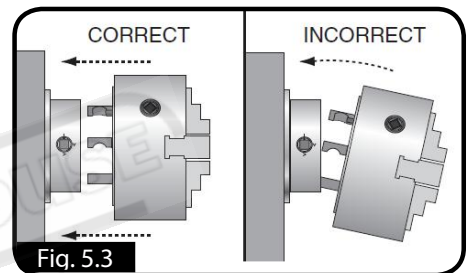

Fig. 5.3

**Note !** Avoid inserting the studs in from an angle or rotating the spindle. This can damage the studs or the cam holes. (Fig 5.3)

When the chuck is fully seated and all the camlocks are tight, check that the cam line is between the two "V" marks on the spindle nose, as shown in Figure 5.4.

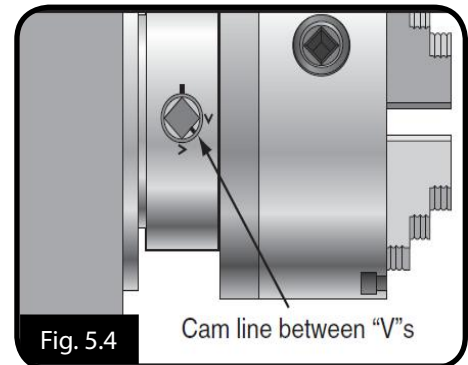

Fig. 5.4

If the cam line is not between the "V" marks when the camlock is tight, the stud may not be installed at the incorrect height.

First check that the line on the cam is flush with the surface of the chuck. If it is not then adjust the stud height as shown (Fig. 5.5). Make sure to re-install the stud locking cap screw after adjustment has been made.

If adjusting the stud height does not correct the problem, try swapping stud positions on the chuck.

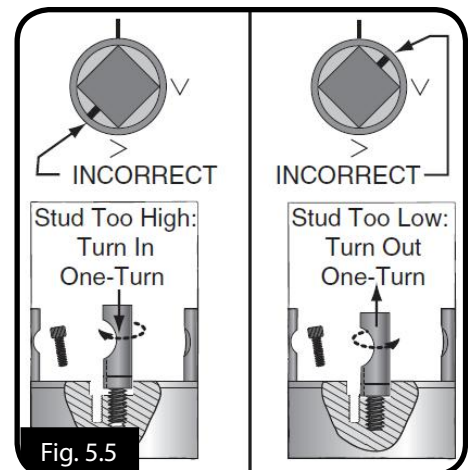

Fig. 5.5

**5.3 SPINDLE SPEEDS**

Using the correct spindle speed is important for getting safe and satisfactory results, as well as maximizing tool life.

To set the spindle speed for your operation, you will need to:

- 1) Determine the best spindle speed for the cutting task and material.
- 2) Configure the lathe controls to produce the required spindle speed.

**Determining Spindle Speed**

Many variables affect the optimum spindle speed to use for any given operation, but the two most important items are the recommended cutting speed for the workpiece material and the diameter of the workpiece, as noted in the formula shown below.

$$\frac{\text{Recommended Cutting Speed (Mtrs/Min) x 1000}}{\text{Diaameter in Millimeters x 3.14}} = \text{RPM}$$

The Fitting & Maching handbook (L341) and some internet sites, provide excellent recommendations for which cutting speeds to use when calculating the spindle speed. These sources also provide a wealth of additional information about the variables that affect cutting speed and they are a good educational resource.

**Example**

Figure 5.6 shows the levers positioned for a spindle speed of 120 RPM

**NOTE:** If the spindle speed levers do not easily adjust into position, rotate the spindle by hand while you apply pressure to the lever. When the gears align, the lever will easily move into place.

If you have trouble rotating the spindle by hand, you can use the spindle key or a chuck key to get additional leverage—just be sure to remove the key when you are done.



Fig. 5.6



**WARNING**

**To avoid damaging gears, ALWAYS make sure the spindle is completely stopped BEFORE moving the spindle speed levers.**

**5.4 TAPER TURNING ATTACHMENT**

Some models of these lathes may be supplied with a Taper Turning Attachment as a standard option.(Fig. 5.7)

The range of the taper is from 0° - 20° included angle. It works in the following way. The deadman clamp cap screws when they are loose, disengage the taper attachment and the lathe is in normal operation.

When the cap screws (Figure 5.8) are used to clamp the deadman clamp against the bedway, the taper turning attachment is engaged.

**Operation**

1. DISCONNECT THE LATHE FROM POWER.
2. Move the carriage, cross slide, and compound rest so your turning tool is at beginning of the taper to be cut.

**NOTE:** Make sure that there is enough travel on the Taper Turning Attachment slide to cover the length of the taper.

3. Using an 8mm hex wrench, tighten both the deadman clamp cap screws so the deadman clamps against the lathe bedway (Fig. 5.8).
4. Using a 6mm hex wrench, loosen both dovetail lock cap screws (Fig. 5.9, 5.10)
5. Turn the taper angle control knob (Fig. 5.11) until you reach the taper angle that you need as indicated by the taper scale (Fig. 5.9).
6. Retighten both dovetail lock cap screws and begin the machining operations.

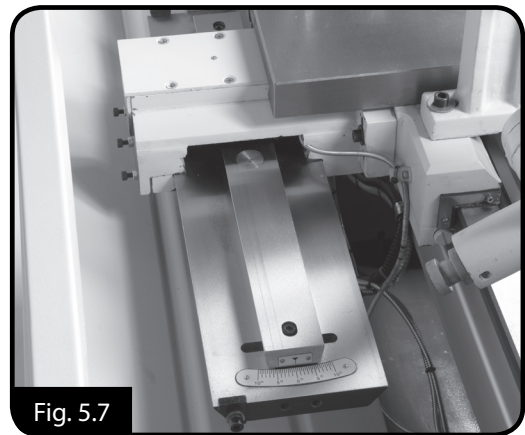

Fig. 5.7

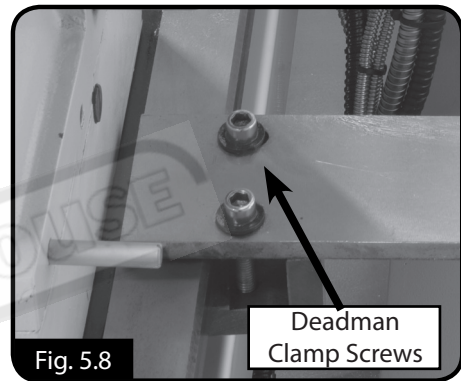

Fig. 5.8

Deadman  
Clamp Screws

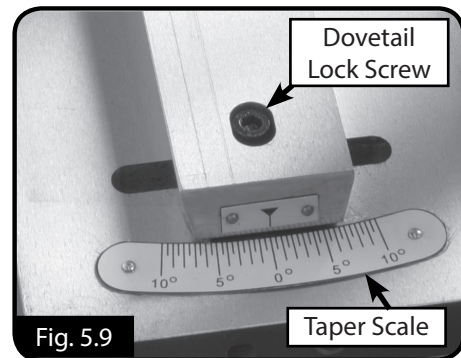

Fig. 5.9

Dovetail  
Lock Screw

Taper Scale

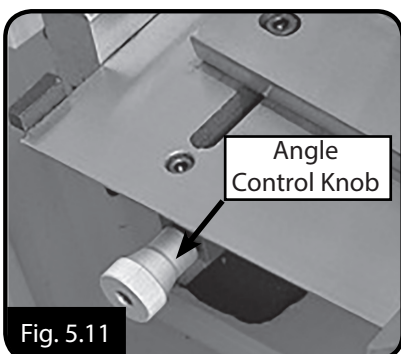

Fig. 5.11

Angle  
Control Knob

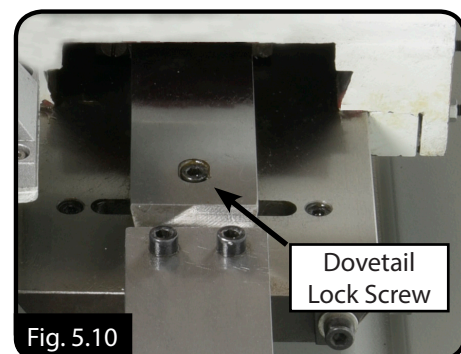

Fig. 5.10

Dovetail  
Lock Screw

## 6. MAINTAINANCE

### 6.1 LUBRICATION TYPE AND FREQUENCY

Use the information in the charts below as a daily guide for lubrication tasks

<b>Assembly</b>	<b>Part</b>	<b>Method</b>	<b>Lubricant</b>	<b>Interval</b>
Headstock	Spindle Gears and Bearings	Oil Bath	Machine Oil	6 Months
Feed Box	Gears and Bearings	Oil Bath	Machine Oil	Check site glass daily and fill as required
Carriage	Gears and Bearings	Oil Bath	Machine Oil	Check site glass daily and fill as required
End Gears	Change gears and quadrant	Oil Can	Machine Oil and Grease	Once per shift
Carriage Slide	Bedway slides	Auto	Machine Oil	Auto Feed
Cross Slide	Slides and Screws	Auto	Machine Oil	Auto Feed
Tailstock	Quill and Screw	Oil Can	Machine Oil	Once per shift
Feed and Lead Screw	Screws and Bearings	Oil Can	Machine Oil	Once per shift

Fig. 6.1

**6.2 LUBRICATION POINTS**

**Headstock**

The headstock utilizes an oil-splash feed lubrication system. The reservoir has the proper amount of oil when the oil level in the sight glass is approximately halfway. (Fig. 6.2) The oil sight glass is located below the spindle speed levers. The oil should be changed every six months by firstly draining the oil by removing the drain plug (Fig. 6.3) then filling by the oil filler plug (Fig. 6.4)



Fig. 6.2  
Sight Glass

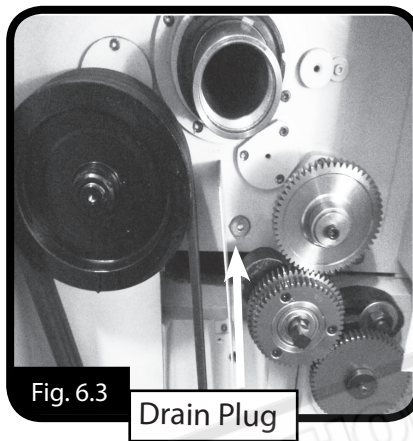

Fig. 6.3  
Drain Plug

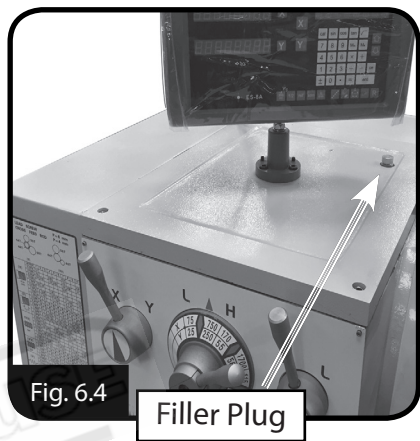

Fig. 6.4  
Filler Plug

**Quick Change Gearbox**

The quick change gearbox is oil-bath lubricated to insure the long life of the gears and bearing. It is recommended the lubricant to be changed every twelve months with a 20W non-detergent oil, or an equivalent gearbox machine oil. The oil level can be checked by viewing the sight glass (Figure 6.5) The oil level should be kept so that the oil is level to the middle of the sight glass.

After the first month of daily operation the following procedure should be done.

1. Drain the gear box. See Fig. 6.5 for the drain plug.
2. Flush the gearbox with some fresh oil to remove any contaminants that may be left from the manufacturing process.
3. Replace the drain plug and fill the gearbox with new oil so that the oil level is halfway up the oil sight glass. The filler plug can be found by removing the cover plate above the gearbox. (See Fig. 6.6)

The gearbox oil should be changed yearly, or more frequently if heavy machine use requires it.

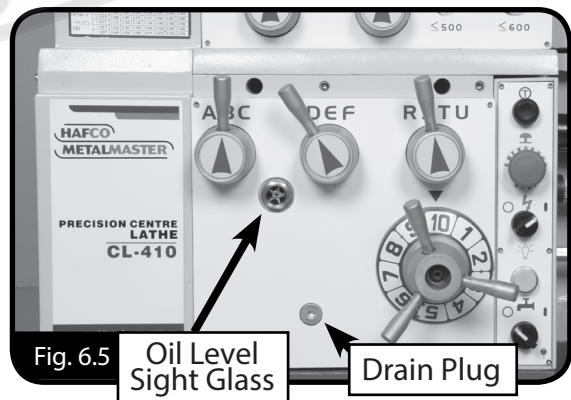

Fig. 6.5  
Oil Level Sight Glass  
Drain Plug

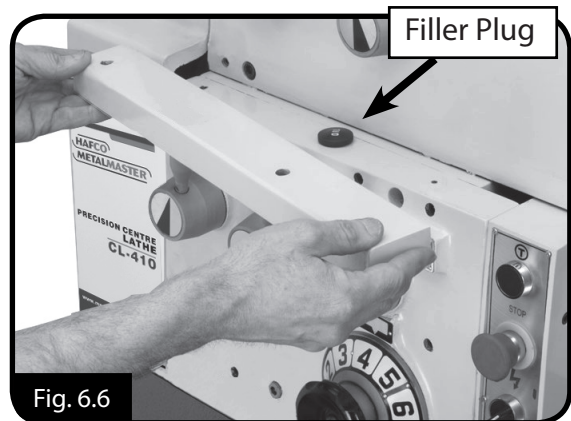

Fig. 6.6  
Filler Plug

## 6.2 LUBRICATION POINTS Cont.

### APRON

The apron oil sight glass is on the front of the apron, as shown in Fig. 6.7. Maintain the oil volume so that the level is approximately halfway in the sight glass.

### Changing Oil & Flushing Reservoir

Small metal particles may accumulate at the bottom of the reservoir with normal use. Therefore, to keep the reservoir clean, drain and flush it at least once a year. Place a catch pan under the apron drain plug (Fig. 6.7), remove the fill plug, (Fig. 6.8) then remove the drain plug and empty the reservoir. Flush the reservoir by pouring a small amount of clean oil into the fill hole and allow it to drain out the bottom. Replace the drain plug, add oil as required, then re-install the fill plug.

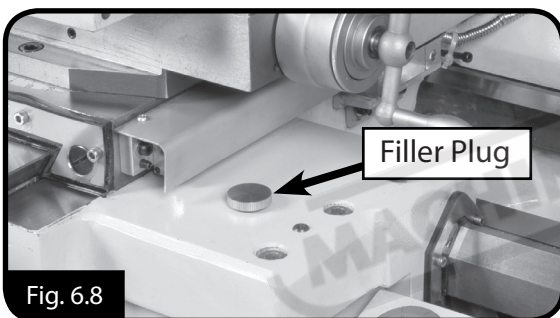

Fig. 6.8

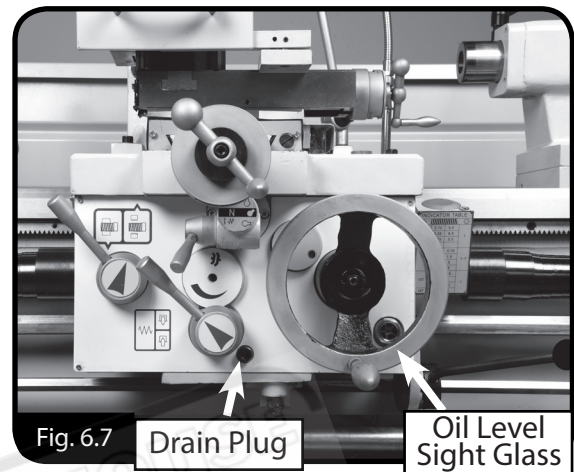

Fig. 6.7

### BEDWAY LUBRICATION

The bed ways are lubricated by an automatic system (Fig. 6.9) which dispenses oil at preset times from the pump and reservoir mounted on the back of the machine. The oil needs to be way oil or 20W grade. The level should be checked daily



Fig. 6.9

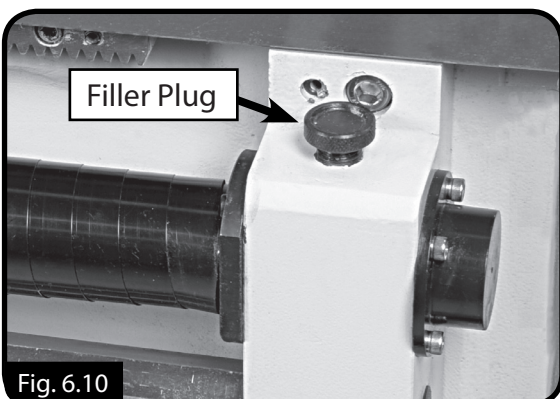

Fig. 6.10

### LEADSCREW LUBRICATION

The lead screw is lubricated from a reservoir system (Fig. 6.10) which is filled from the filler plug on the lead screw support on the end of the machine. The oil needs to be 20W grade.

**BALL OILERS**

Proper lubrication of ball oilers is done with a pump-type oil can that has a plastic or rubberized cone tip, sometimes supplied with the accessories. Lubricate the ball oilers before and after machine use, and more frequently under heavy use. When lubricating ball oilers, first clean the outside surface to remove any dust or grime. Push the tip of the oil can nozzle against the ball oiler to create a hydraulic seal, then pump the oil can once or twice. It is important not to press the ball oiler too hard with the nozzle of the oil can as it may cause the ball to jam in the open position, allowing dirt to enter. If you see sludge and dirt coming out of the lubrication area, keep pumping the oil can until the oil runs clear. When finished, wipe away any excess oil.

- Cross-slide leadscrew & slides
- Compound-rest leadscrew & slides (Fig 6.11)
- Carriage handwheel (Fig.6.13)
- Feed selection lever gearing
- Tailstock ball oilers (Fig. 6.12)

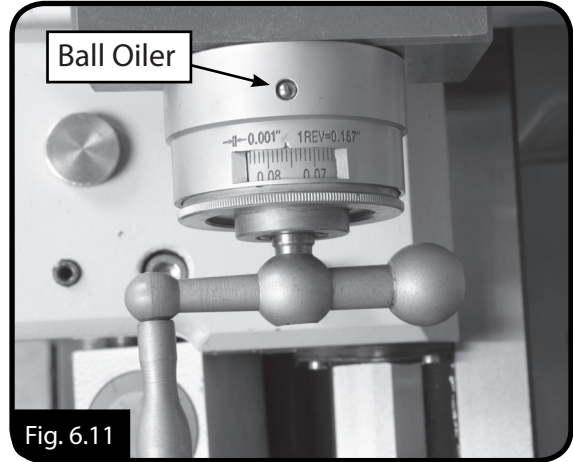

Fig. 6.11

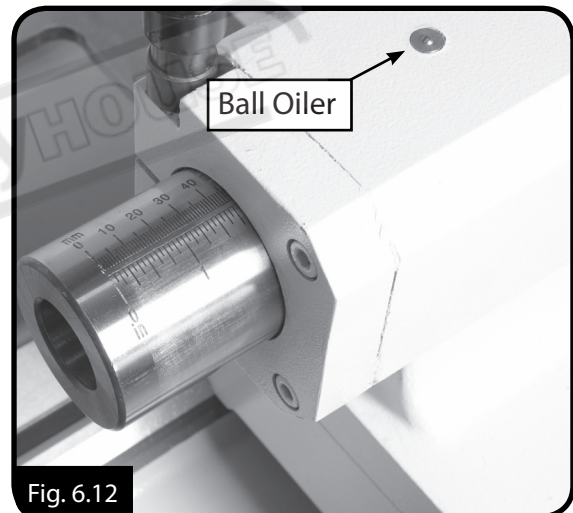

Fig. 6.12

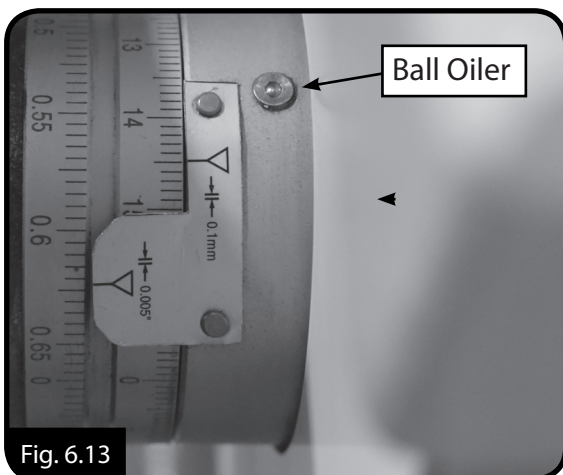

Fig. 6.13

### 6.3 FEED CLUTCH ADJUSTMENT

This lathe is equipped with a cone type feed clutch. The clutch is designed to protect the apron feed system from overloading. The feed clutch is set by the factory, however, after the lathe has been used, it may require some readjustment.

#### To adjust the clutch release point:

1. With a 5mm hex wrench, turn the center cap screw ("A" in Fig. 6.14) clockwise to increase the clutch holding power, and turn counterclockwise to decrease the amount of clutch holding power.
2. Start the lathe,
3. Engage the power feed ("B" in Fig. 6.14) and hold the longitudinal feed handwheel with one hand. The clutch should release within a few seconds without much pressure of handwheel rotation. This holding force is approximately 12 kgs.
4. If the amount of pressure is not correct, adjust the clutch screw again as required to achieve the correct setting.

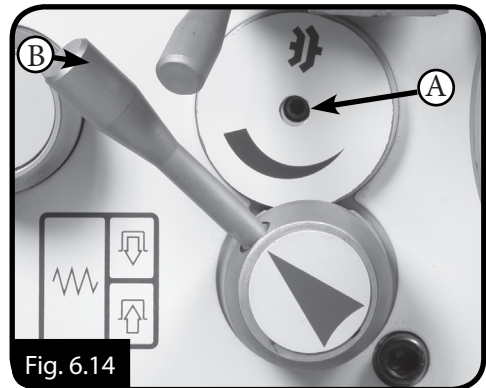

Fig. 6.14

### 6.4 GIB ADJUSTMENT

The goal when adjusting the cross slide, tailstock, saddle, and compound rest gib screws is to remove sloppiness in the ways without causing the slides to bind. Loose gibs will cause a poor finish on the workpiece and may cause undue wear on the slide. Over-tightening may cause premature wear on the slide, lead screw, and nut.

The cross slide, (Fig. 6.15) tailstock, (Fig. 6.16) saddle, and compound rest gibs use a tapered piece of cast iron which is held in position by two gib screws at opposing ends of the gib. When these opposing front and rear gib adjustment screws (Fig. 6.15) are turned in opposite directions from each other, "One screw clockwise and the other counterclockwise, or visa versa" the single gib will be moved in or out to fill the gap between the slide and the dovetail. By doing this the play in the slide is removed. If more play is needed adjust the screws so the gib is moved and held in the opposite direction.

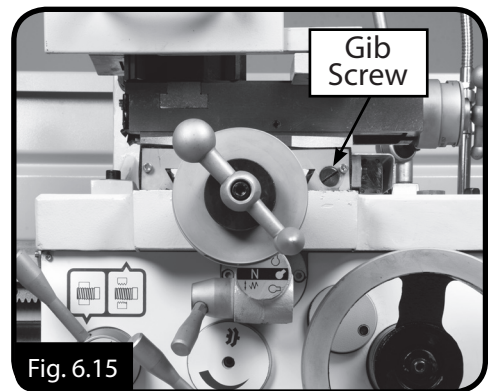

Fig. 6.15

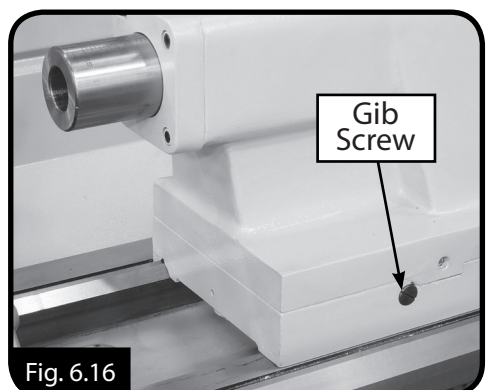

Fig. 6.16

### 6.5 BRAKE AND MICRO SWITCH ADJUSTMENT

The foot brake is linked to a Micro Switch. This needs to be maintained with a clearance of 3-5mm from the brake cam to the finger of the Micro Switch. Before making any changes always disconnect the power to the machine to ensure the safety of the service personnel and reduce any fading of brake material. After stopping the machine with the foot brake, the spindle control lever needs to be activated again to make the spindle revolve again. (Fig. 6.17)

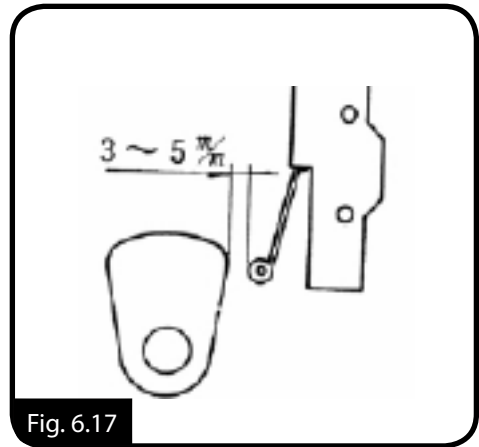

Fig. 6.17

### 6.6 ADJUSTING THE LEAD SCREW BACKLASH

The machine is supplied from the factory with the correct backlash already adjusted but some times through general use this may need to be adjusted. Incorrect backlash is mainly noticed when during the threading processing, the threads are consistant or cross threading occurs. This is usually caused by incorrect backlash on Lead screw. To fix this problem adjust the packing nut appropriately on rear side of the Lead screw. Open the cover on rear side of Lead screw Bracket, turn nut "A" tightly with the backlash removed. A check of the result can be made by pushing down Half Nut Handle, and turning the apron Hand-wheel. Place your hand on the contact point between Gear Box and Lead screw. There should be no lateral movement. (Fig. 6.18) Once completed replace the "A" nut side cover.

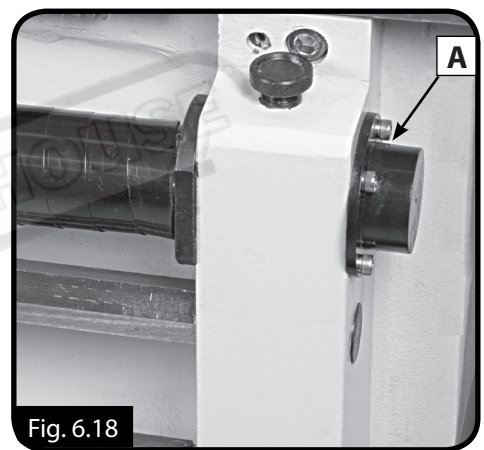

Fig. 6.18

### 6.7 COOLANT PUMP & TANK

The coolant pump and reservoir are located in the base behind the vented cover on the tailstock end of the lathe and requires regular maintenance.

1. Remove the access cover at the rear of the lathe (Fig. 6.19).
2. Pump the old cutting fluid out of the reservoir and dispose of it according to local laws.
3. Using a magnet, brush, and rags clean out metal chips from the bottom of the reservoir. Flush with hot soapy water if required.
4. Refill the reservoir with water soluble cutting fluid. Follow the manufacturer's instructions for mixing.
5. Open the valve on the coolant nozzle and turn the coolant pump ON to prime the coolant system.
6. Replace the access cover.

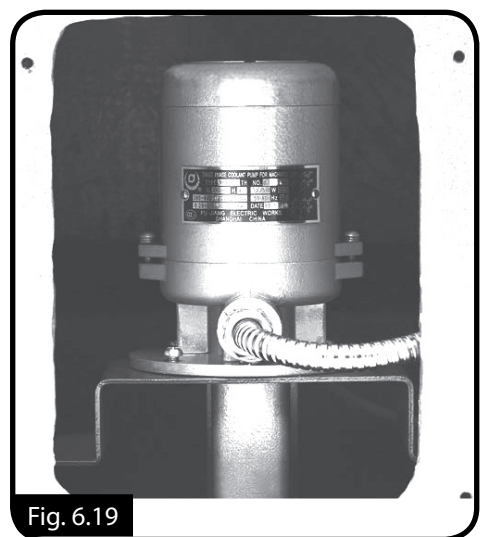

Fig. 6.19

**6.8 TROUBLE SHOOTING**

<b>Symptoms</b>	<b>Possible Cause</b>	<b>Possible Solution</b>
Machine does not start or circuit breaker trips	Foot brake is engaged	Check to see if the foot brake is up.
	Emergency button needs to be reset.	Rotate the emergency stop button until it pops out and resets
	Chuck guard open	Close chuck guard
	Fuse has blown in the machines electrical box.	Replace fuse. Determine if overload is due to heavy operation; ensure power source has high enough voltage
	Power supply has switched OFF	Ensure power supply is ON and the voltage is correct
	Thermal overload relay has tripped.	The wiring connection is correct .
	Wall fuse or circuit breaker is blown/tripped; caused by a short in electrical system;	Verify circuit is rated for machine amp load; troubleshoot and repair cause of overload; Have a qualified electrician replace weak breaker; find/repair electrical short.
	Start capacitor at fault	Test/replace if faulty.
Motor stalls or is under powered	Belts slipping	Check the tension of the belts and replace if worn.
	Faulty run capacitor	Test and replace if faulty.
	Motor faulty	Test and replace if faulty
Loud noises coming from near the motor	Pulley keys worn or are missing or set screws loose	Inspect keys and set screws. Replace or tighten as required.
	Motor fan is loose.	Tighten the fan and reset the fan cover
Motor is noisy when the machine is cutting	Depth of cut is too deep	Reduce the depth of cut or feed rate.
	Speed or feed rate is wrong	Consult the speed and feed charts in the machinery handbook
	Cutting tool is dull	Replace or sharpen the cutting tool
Machined surface finish is rough.	Incorrect spindle speed or feed rate.	Adjust for appropriate spindle speed and feed rate.
	Blunt tool or poor tool selection	Sharpen tooling or select a better tool for the intended operation.
	Tapered gibs not correctly adjusted.	Tighten gibs

**6.3 TROUBLE SHOOTING**

<b>Symptoms</b>	<b>Possible Cause</b>	<b>Possible Solution</b>
Entire machine vibrates excessively upon startup and while running	Workpiece is unbalanced. Loose or damaged belt(s). V-belt pulleys not properly aligned. Worn or broken gear present. Chuck or faceplate has become unbalanced. Spindle bearings badly worn.	Reinstall workpiece so it is as centered with the spindle bore as possible. Tighten/replace the belt as necessary. Align the V-belt pulleys. Inspect gears and replace if necessary. Rebalance chuck or faceplate; contact a local machine shop for help. Replace spindle bearings.
Bad surface finish.	Wrong RPM or feed rate. Dull tooling or poor tool selection. Too much play in gibs. Tool too high.	Adjust for appropriate RPM and feed rate. Sharpen tooling or select a better tool for the intended operation. Tighten gibs. Lower the tool position.
Can't remove tapered tool from tailstock quill.	Quill had not retracted all the way back into the tailstock. Debris on the taper before inserting	Turn the quill handwheel until it forces taper out of quill. Always make sure that taper surfaces are clean.
Cross slide, compound slide, or carriage feed has sloppy operation	Gibs are out of adjustment. Handwheel is loose. Mechanism worn or needs adjustment.	Tighten gib screw(s). Tighten handwheel fasteners. Tighten any loose fasteners on lead screw mechanism.
Cutting tool or machine components vibrate excessively during cutting	Tool holder not tight enough. Cutting tool sticks too far out of tool holder; lack of support. Gibs are out of adjustment. Dull cutting tool. Incorrect spindle speed or feed rate.	Check for debris, clean, and retighten. Reinstall cutting tool so no more than 1/3 of the total length is sticking out of tool holder. Tighten gib screws at affected component. Replace or resharpen cutting tool. Use the recommended spindle speed.
Inaccurate turning results from one end of the workpiece to the other.	Headstock and tailstock are not properly aligned with each other.	Realign the tailstock to the headstock spindle bore center line.
Chuck jaws won't move or don't move easily.	Chips lodged in the jaws.	Remove jaws, clean and lubricate chuck threads, and replace jaws.

**6.3 TROUBLE SHOOTING**

<b>Symptoms</b>	<b>Possible Cause</b>	<b>Possible Solution</b>
Carriage won't feed.	Gears are not all engaged. Gears are broken. Loose screw on the feed handle	Adjust gear positions. Replace. Tighten.
Carriage hard to move.	Carriage lock is tightened down. Chips have loaded up on bedways. Bedways are dry and in need of lubrication. Longitudinal stops are interfering. Gibs are too tight.	Check to make sure the carriage lock bolt is fully released. Frequently clean away chips that load up during turning operations. Lubricate bedways and handles. Check to make sure that stops are floating and not hitting the center stop. Loosen gib screw(s) slightly.
Gear change levers will not shift into position	Gears not aligned in headstock.	Rotate spindle by hand until gear falls into place
Loud, repetitious noise coming from machine.	Gears not aligned in headstock or no backlash. Broken gear or bad bearing. Workpiece is hitting stationary object.	Adjust gears and establish backlash. Replace broken gear or bearing. Stop lathe immediately and correct interference problem..
Tailstock quill will not feed out of tailstock.	Quill lock knob is tightened down.	Turn knob counterclockwise.

# SPARE PARTS SECTION

The following section covers the spare parts diagrams and lists that were current at the time this manual was originally printed. Due to continuous improvements of the machine, changes may be made at any time without notification.

## HOW TO ORDER SPARE PARTS

1. Have your machines **Model Number, Serial Number & Date of Manufacture** on hand, these can be found on the specification plate mounted on the machine
2. A scanned copy of your parts list/diagram with required spare part/s identified
3. Go to [www.machineryhouse.com.au/contactus](http://www.machineryhouse.com.au/contactus) and fill out the enquiry form attaching a copy of scanned parts list.

## CONTENTS

Electrical Diagrams.....	43
CL-410 Headstock Parts.....	46
CL-410 Headstock Parts List.....	52
CL-460 Headstock Parts.....	57
CL-460 Headstock Parts List.....	61
Gearbox Parts.....	66
Gearbox Parts List.....	70
Saddle Parts.....	74
Saddle Parts List.....	77
Apron Parts.....	81
Apron Parts List.....	84
Tailstock Parts.....	88
Tailstock Parts List.....	89
Bed Assembly Parts.....	91
Bed Assembly Parts List.....	95
Fixed Steady Parts.....	100
Fixed Steady Parts List.....	101
Traveling Steady Parts.....	102
Traveling Steady Parts List.....	103

**A. ELECTRICAL DIAGRAM**

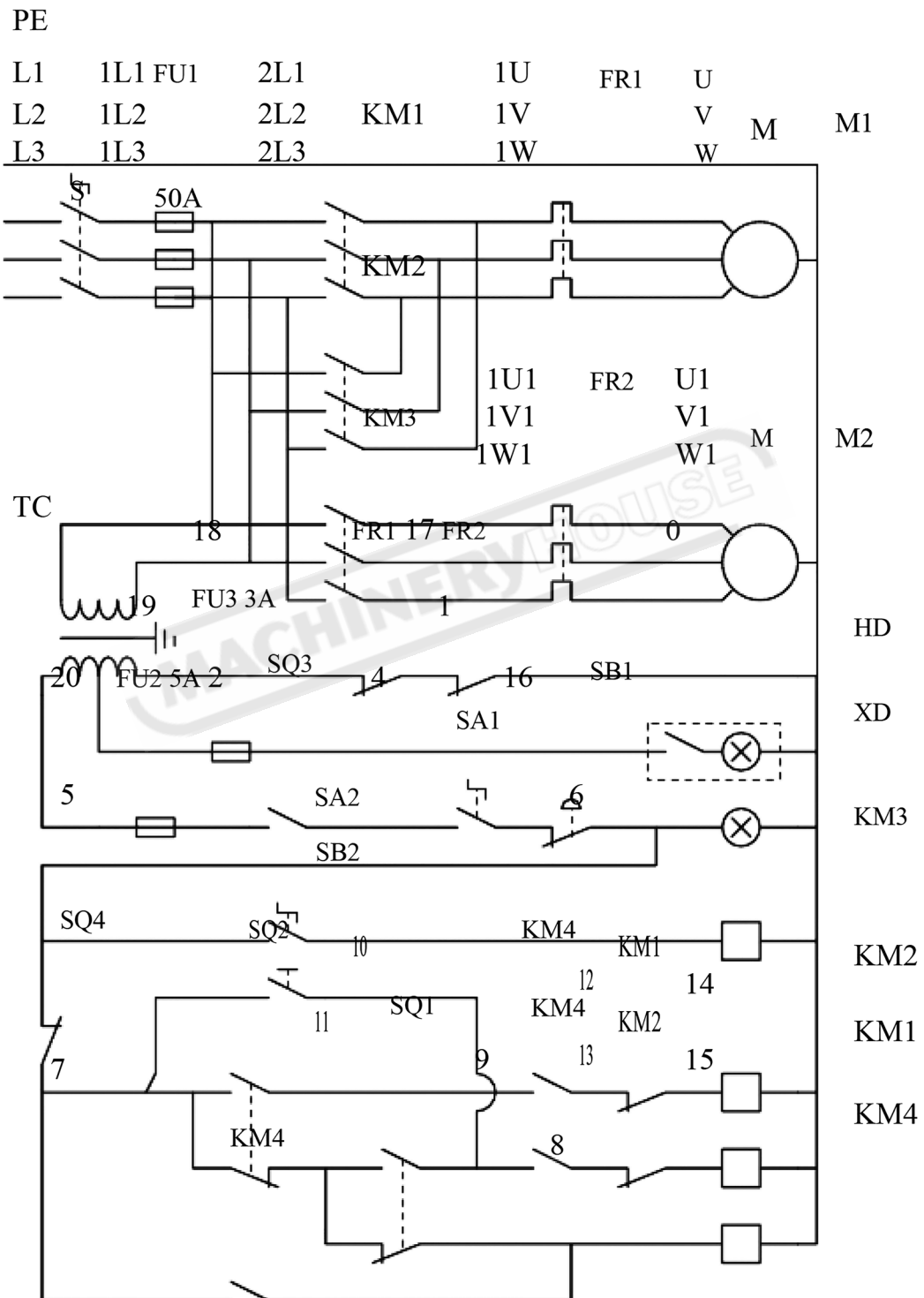

**A. ELECTRICAL DIAGRAM Cont.**

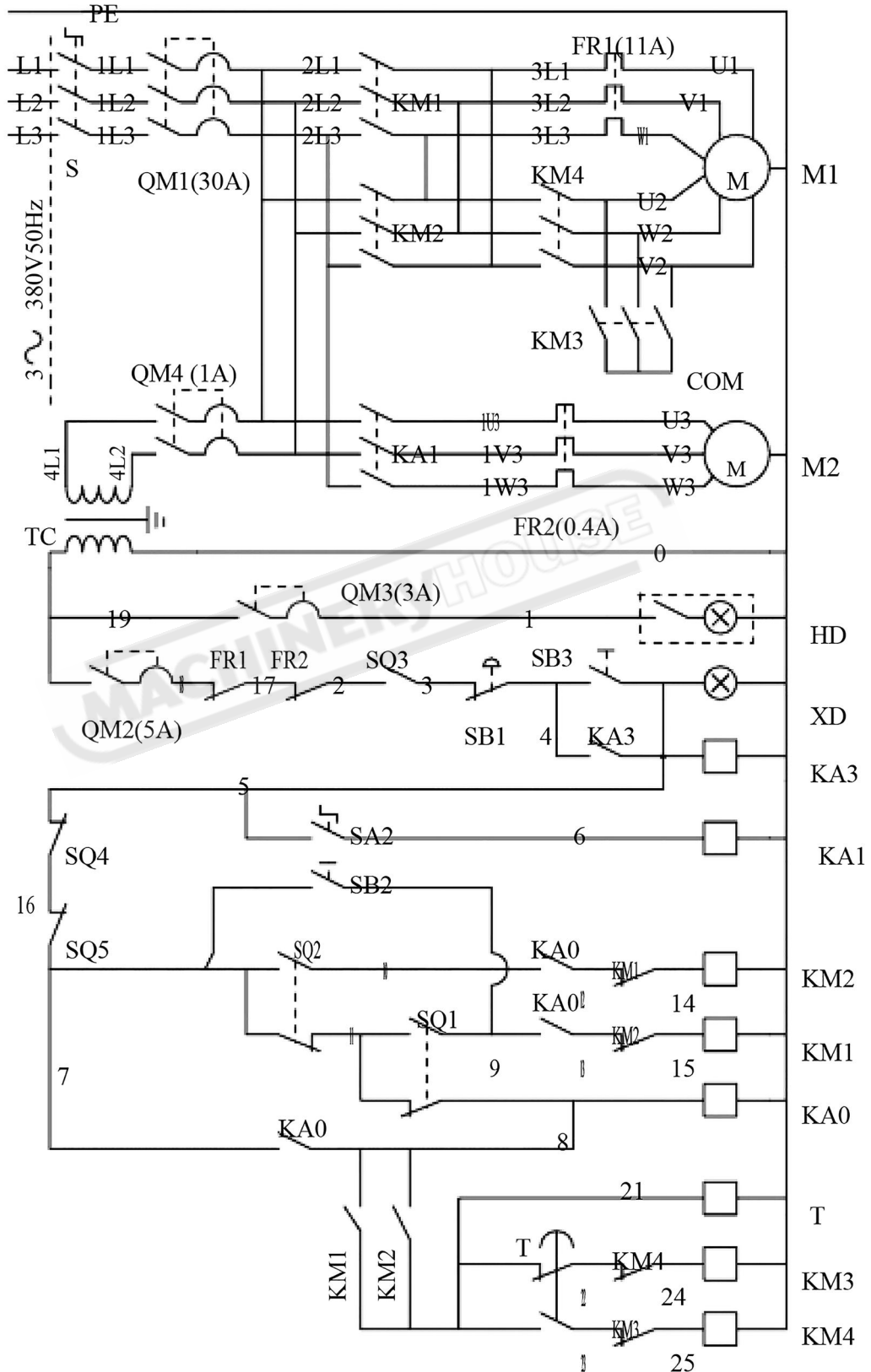

**A. ELECTRICAL DIAGRAM Cont.**

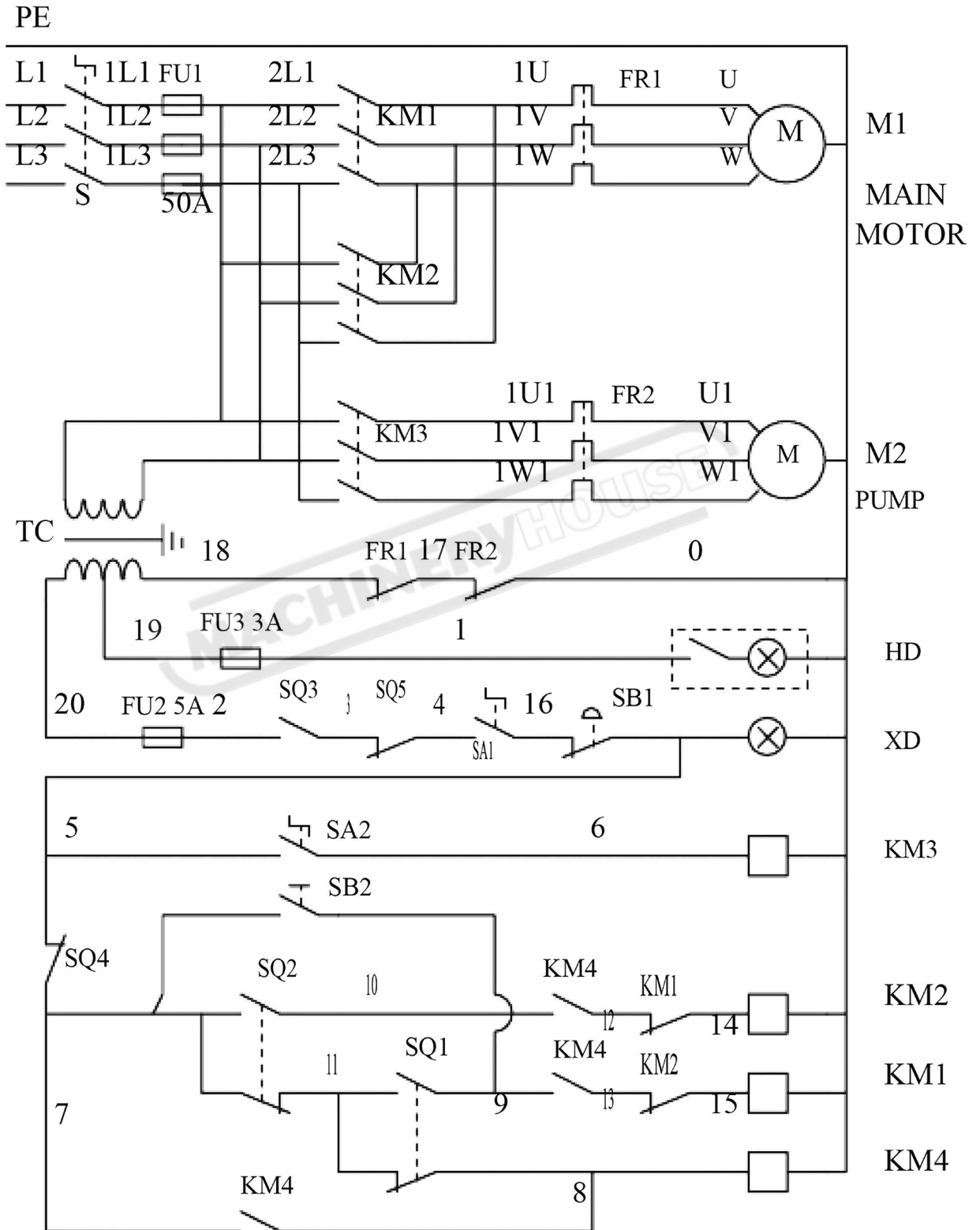

WIRINGDIAGRAM

**CL-410 HEADSTOCK PARTS**

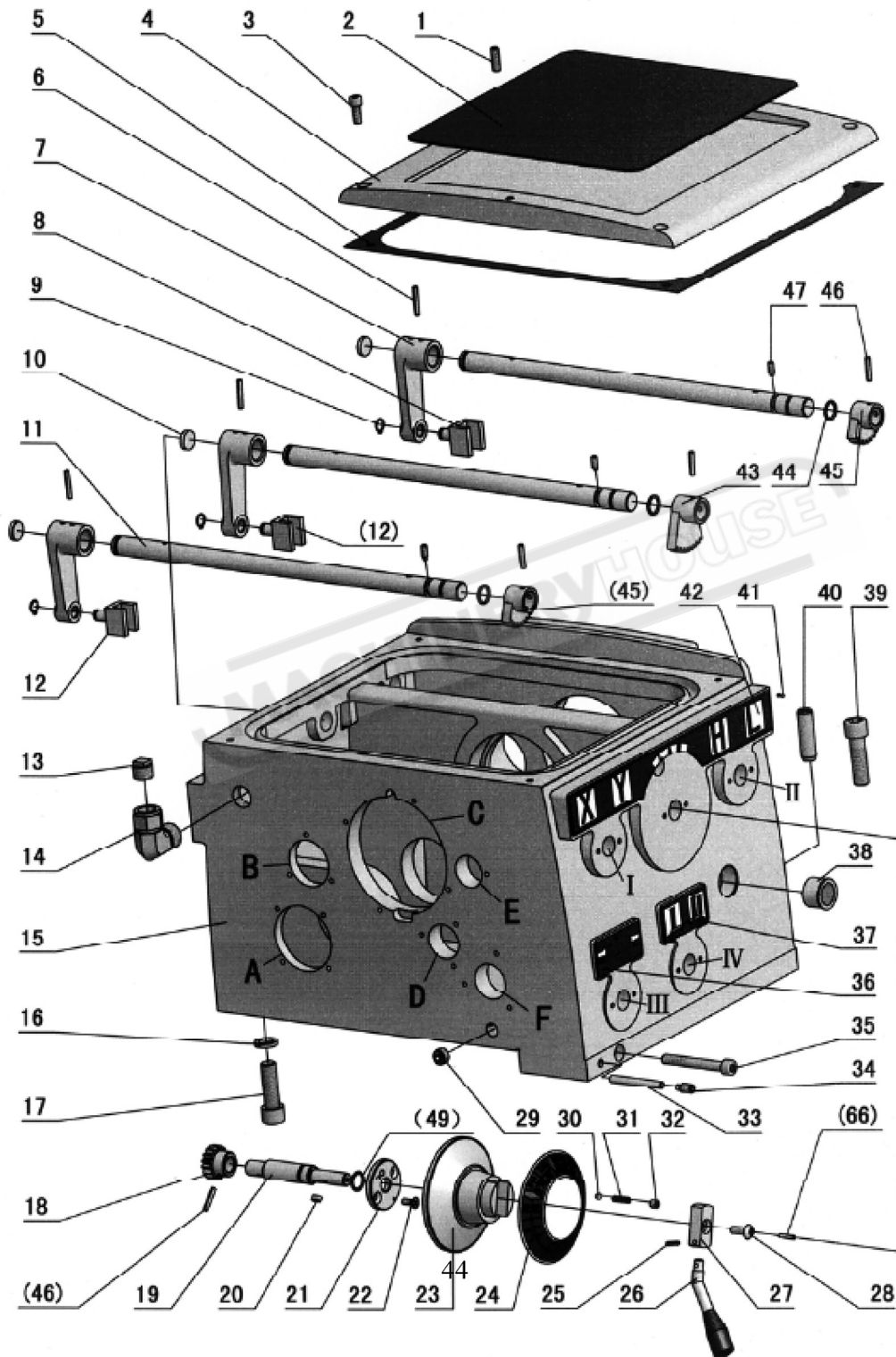

**CL-410 HEADSTOCK PARTS Cont.**

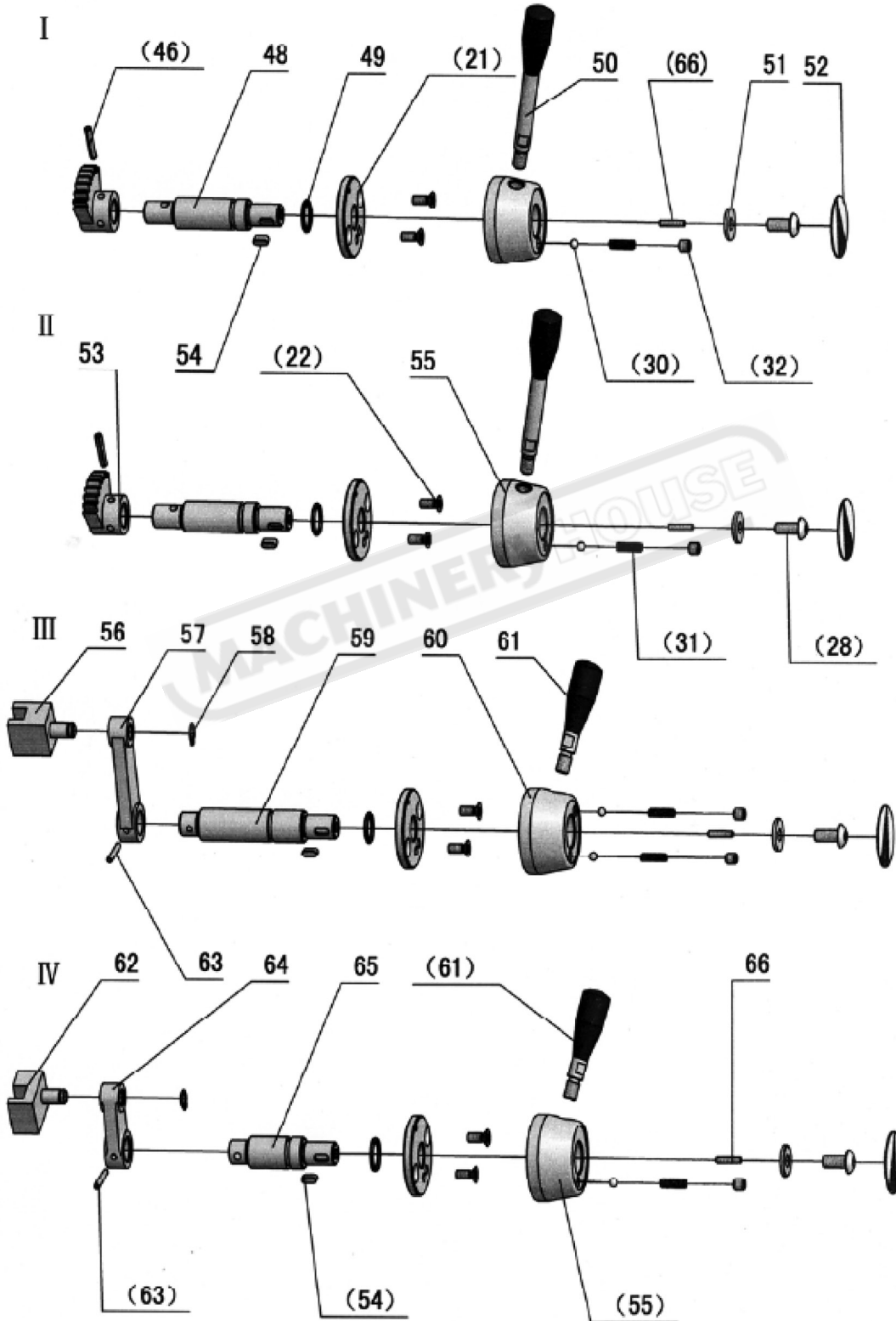

**CL-410 HEADSTOCK PARTS Cont.**

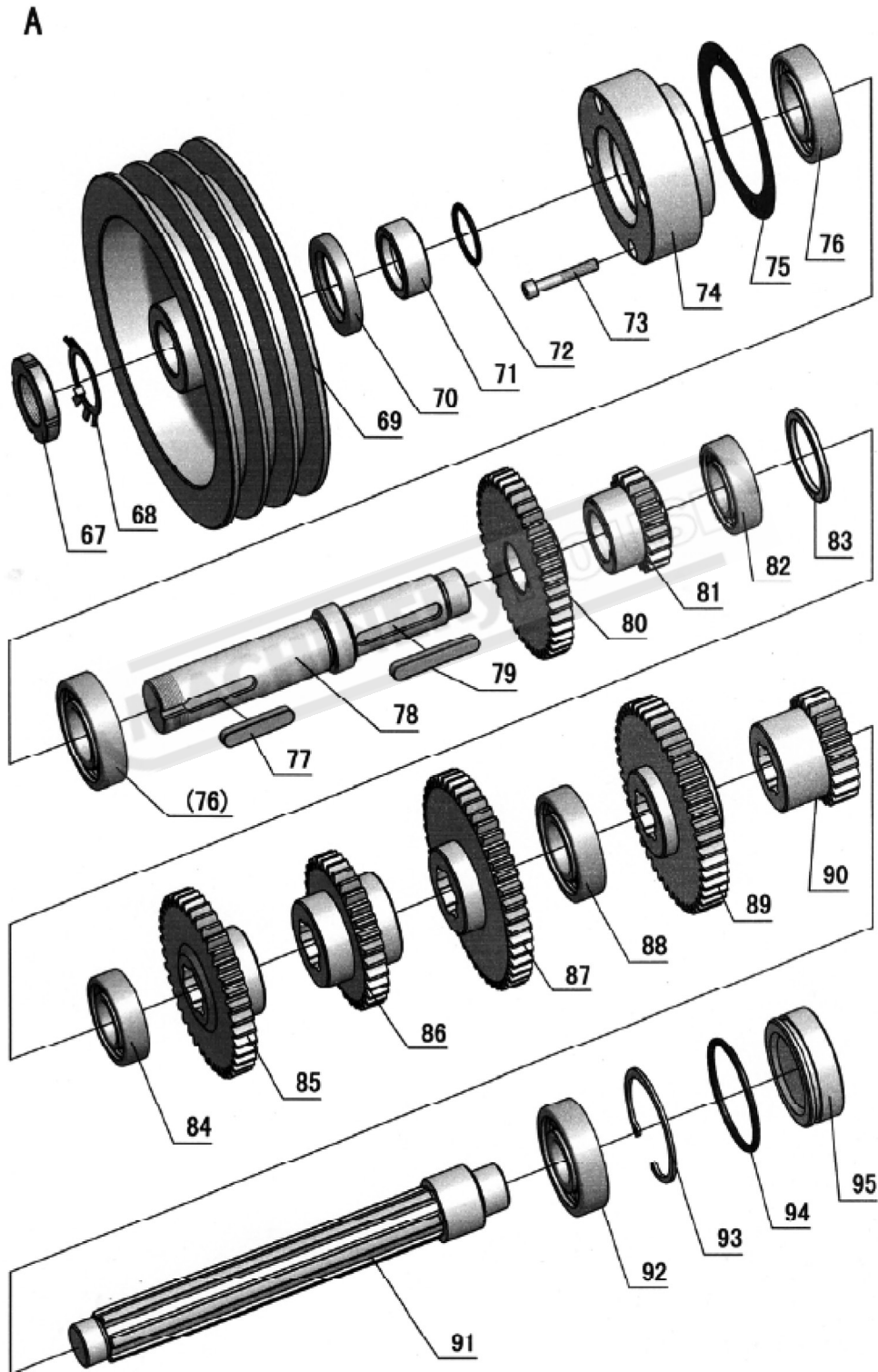

**CL-410 HEADSTOCK PARTS Cont.**

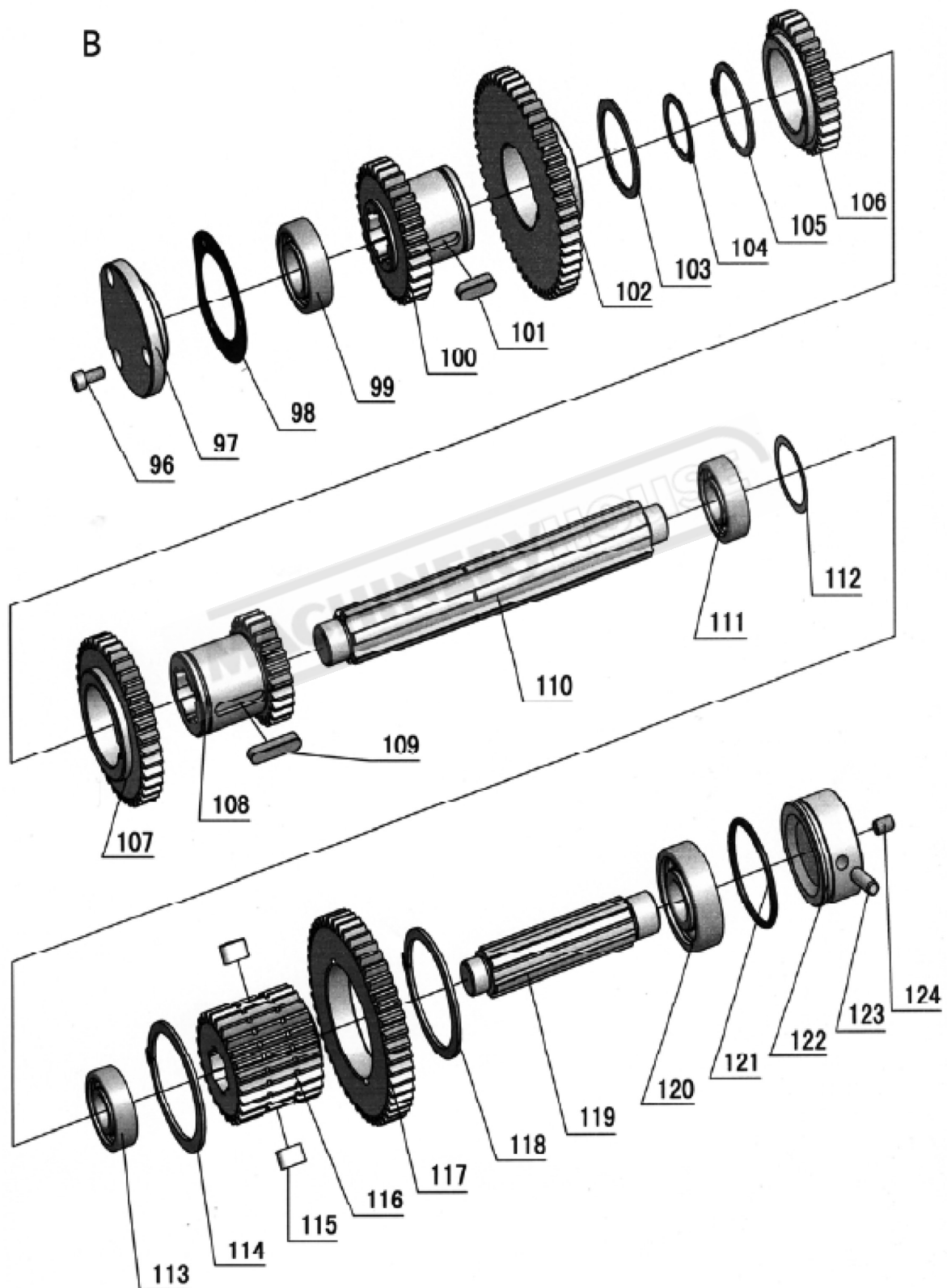

**CL-410 HEADSTOCK PARTS Cont.**

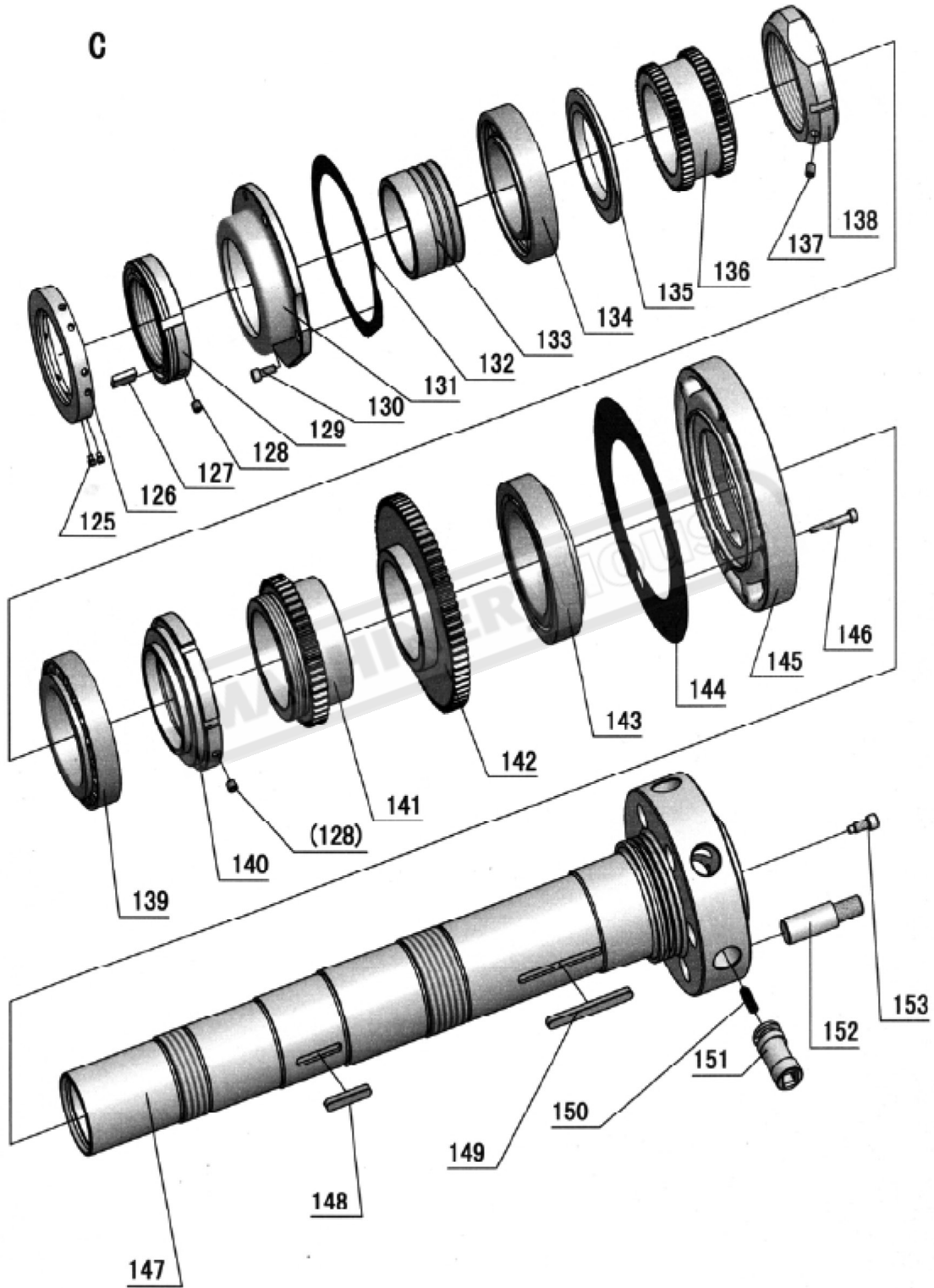

**CL-410 HEADSTOCK PARTS Cont.**

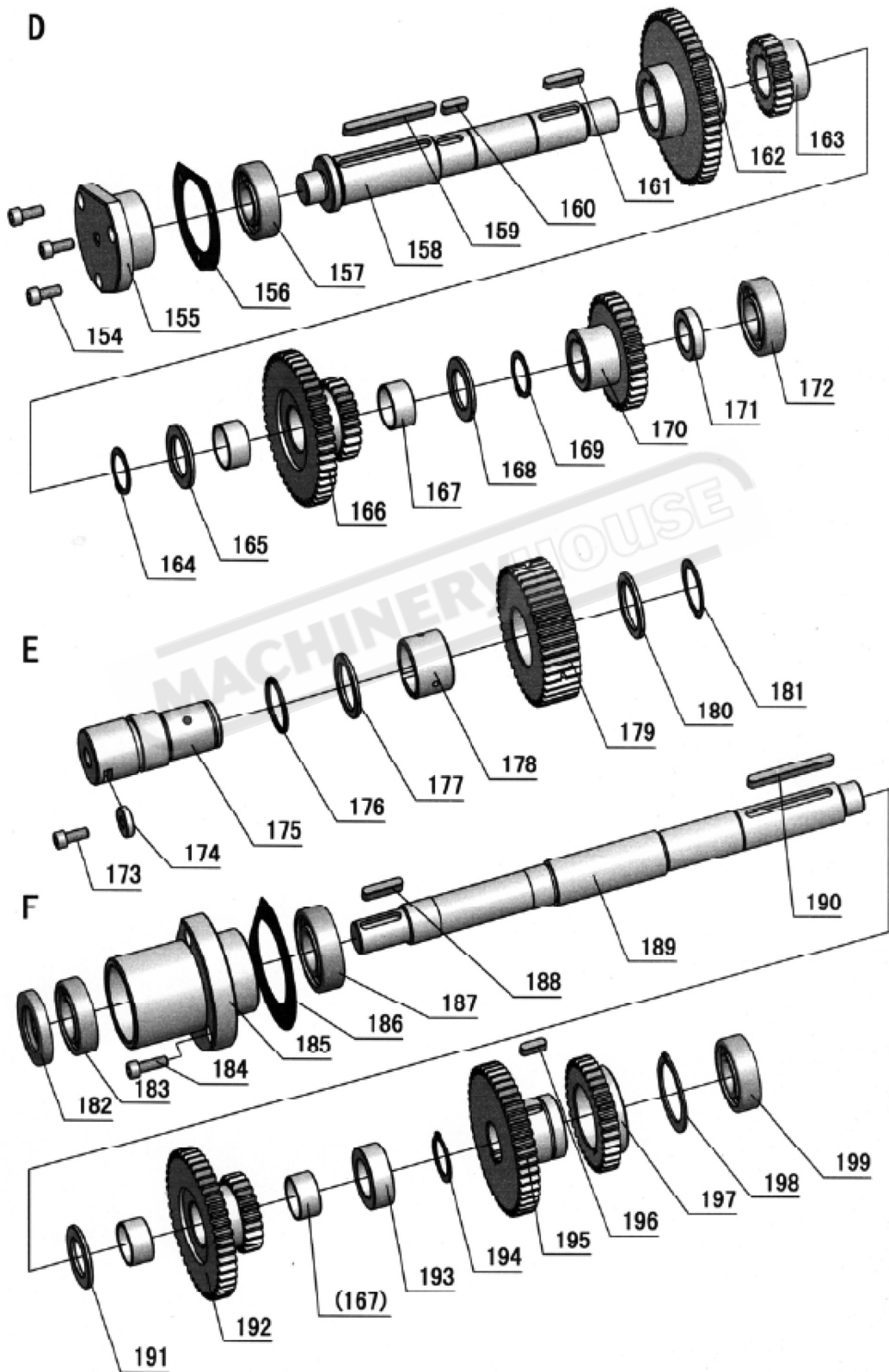

**CL-410 HEADSTOCK PARTS LIST**

No	Part No.	Item	Specification	Qty.
1	GB77-85	Screw	M8×25	1
2	RUN6246-101003	Cover Dress		1
3	GB70-85	Screw	M8×20	4
4	RUN6246-101002	Headstock Cover		1
5	RUN6246-101002-1	Sealed Mat		1
6	GB879-86	Spring Pin	5×30	3
7	RUN6246-101060	Lever		3
8	RUN6246-101062	Fork		1
9	GB894.1-86	Snap Ring	12	3
10	RUN6246-101083	Plug		3
11	RUN6246-101059	Shaft		3
12	RUN6246-101061	Fork		2
13	SB4032-65	Plug	20	1
14	SB4010-65	Tube Fitting	20	1
15	RUN6141-101001	Headstock Casting		1
15	RUN6246H-101001	Headstock Casting		1
16	GB93-87	Washer	M16	3
17	GB70-85	Screw	M16×55	3
18	RUN6246-101063	Gear		1
19	RUN6246-101065-1	Shaft		1
20	GB1096-79	Key	5×12	1
21	RUN6246-101067	Fix Black		5
22	GB819-85	Screw	M6×16	10
23	RUN6246-101077-1	Handel		1
24	RUN6246-101097	Plate		1
25	GB879-86	Spring Pin	4×20	1
26	RUN6246-101077-3	Lever		1
27	RUN6246-101077-2	Fix Bracket		1
28	RUN6246-101088	Round Head Screw		5
29	G38-3A	Oil Plug	Z 3/8"	1
30	GB308-84	Steel Ball	1/4"	6
31	RUN6246-101066	Spring		6
32	GB77-85	Screw	M8×8	6
33	RUN6246-101080	Pin	10×60	1
34	GB79-85	Screw	M10×20	1
35	GB70-85	Screw	M10×110	1
36	RUN6246-101098	Plate		1
37	RUN6246-101100	Plate		1
38	R51-5A	Oil Sight Glass	20	1
39	GB70-85	Screw	M16×45	3

**CL-410 HEADSTOCK PARTS LIST Cont.**

No	Part No.	Item	Specification	Qty.
40	GB120-86	Pin	16×55	1
41	GB827-86	Rivet	2×5	24
42	RUN6246-101096	Plate		1
43	RUN6246-101063-1	Gear		1
44	GB1235-76	O-Ring	20×2.4	3
45	RUN6246-101064-1	Gear		2
46	GB879-86	Spring Pin	5×26	6
47	GB79-85	Screw	M6×16	3
48	RUN6246-101065	Shaft		2
49	GB1235-76	O-Ring	22×2.4	5
50	RUN6246-101072	Lever		2
51	RUN6246-101070-1	Washer		4
52	RUN6246-101099	Plate		4
53	RUN6246-101064	Gear		2
54	GB1096-79	Key	5×12	4
55	RUN6246-101071	Lever Head		3
56	RUN6141-101075A	Fork		1
57	RUN6246-101074-1	Lever		1
58	GB894.1-86	Snap Ring	10	2
59	RUN6141-101073A	Shaft		1
60	RUN6246-101077A	Handle		1
61	RUN6246-102056-1	Lever		2
62	RUN6141-101079	Fork		1
63	GB879-86	Spring Pin	4×26	2
64	RUN6141-101074A	Lever		1
65	RUN6141-101078A	Shaft		1
66	GB77-85	Screw	M4×20	5
67	GB812-88	Nut	M30×1.5	1
68	GB858-88	Nut	30	1
69	RUN6246-101011	Pulley		1
70		Oil Seal	TC55×42×9	1
71	RUN6246-101009	Spacer		1
72	GB1235-76	O-Ring	36×3.5	1
73	GB70-85	Screw	M6×40	4
74	RUN6246-101010	Bearing Cover		1
75	RUN6246-101010-1	Bealed Mat		1
76	GB278-89	Ball Bearing	80206	2
77	GB1096-79	Key	8×45	1
78	RUN6246-101005	Shaft		1
79	GB1096-79	Key	8×55	1

**CL-410 HEADSTOCK PARTS LIST Cont.**

No	Part No.	Item	Specification	Qty.
80	RUN6246-101008	Gear		1
81	RUN6246-101007	Gear		1
82	GB278-89	Ball Bearing	80205	1
83	RUN6246-101006	Spacer		1
84	GB278-89	Ball Bearing	80205	1
85	RUN6246-101014	Gear		1
86	RUN6246-101015	Gear		1
87	RUN6246-101016	Gear		1
88	GB278-89	Ball Bearing	80206	1
89	RUN6246-101017	Gear		1
90	RUN6246-101018	Gear		1
91	RUN6246-101013	B Shaft		1
92	GB278-89	Ball Bearing	80305	1
93	GB893.1-86	Snap Ring	62	1
94	GB3452.1-82	O-Ring	56x2.65	1
95	RUN6246-101019-1	Plug		1
96	GB70-85	Socket Head Cap Screw	M6x14	3
97	RUN6246-101032	Cover		1
98	RUN6246-101032-1	Sealed Mat		1
99	GB278-89	Ball Bearing	80205	1
100	RUN6246-101030	Gear		1
101	GB1096-79	Key	8x25	1
102	RUN6246-101031	Gear		1
103	GB894.1-86	Snap Ring	50	1
104	GB894.1-86	Snap Ring	34	1
105	GB894.1-86	Snap Ring	48	1
106	RUN6246-101029	Gear		1
107	RUN6246-101028	Gear		1
108	RUN6246-101027	Gear		1
109	GB1096-79	Key	8x35	1
110	RUN6246-101026	A Shaft		1
111	GB278-89	Ball Bearing	80204	1
112	RUN6246-101025	Spacer		1
113	GB278-89	Ball Bearing	80204	1
114	GB894.1-86	Snap Ring	68	1
115	RUN6246-101023-1	Key		2
116	RUN6246-101023	Gear		1
117	RUN6246-101024	Gear		1
118	GB894.1-86	Snap Ring	68	1
119	RUN6246-101022	C Shaft		1

**CL-410 HEADSTOCK PARTS LIST Cont.**

No	Part No.	Item	Specification	Qty.
120	GB278-89	Ball Bearing	80305	1
121	RUN6246-101019-2	Washer		1
122	GB893.1-86	Snap Ring	62	1
123	GB3452.1-82	O-Ring	56×2.65	1
124	RUN6246-101019-1	Plug		1
125	GB79-85	Screw	M6×8	4
126	RUN6246-101044	Balance Piece		1
127	RUN6246-101043-1	Brass		1
128	GB77-85	Screw	M8×8	2
129	RUN6246-101043	Set Nut		1
130	GB70-85	Screw	M6×16	4
131	RUN6246-101042	Rear Bearing Cover		1
132	RUN6246-101042-1	Sealed Mat		1
133	RUN6246-101041	Cycle Oil Ring		1
134	GB276-89	Ball Bearing	215	1
135	RUN6246-101040	Oil Ring		1
136	RUN6246-101039	Gear		1
137	GB77-85	Screw	M8×10	1
138	RUN6246-101038	Set Nut		1
139	GB297-84	Taper Roller	D2007117E	1
140	RUN6246-101037	Set Nut		1
141	RUN6246-101036	Gear		1
142	RUN6246-101035	Gear		1
143	GB297-84	Taper Roller	D2007118E	1
144	RUN6246-101034-1	Sealed Mat		1
145	RUN6246-101034-2	Front Bearing Cover		1
146	GB70-85	Socket Head Cap Screw	M6×40	5
147	RUN6246-101033-01	Spindle	D1-6	1
148	GB1096-79	Key	8×45	1
149	GB1096-79	Key	8×85	1
150	RUN6246-101082-1	Spring		6
151	RUN6246-101081	Cam Lock		6
152	RUN6246-101082	Spring		6
153	RUN6246-101087	Screw		6
154	GB70-85	Screw	M6×16	3
155	RUN6246-101054	Cover		1
156	RUN6246-101054-1	Sealed Mat		1
157	GB278-89	Ball Bearing	80204	1
158	RUN6141-101049-1	C Shaft		1
159	GB1096-79	Key	6×65	1

**CL-410 HEADSTOCK PARTS LIST Cont.**

No	Part No.	Item	Specification	Qty.
160	Key	Key	6×18	1
161	Key	Key	6×28	1
162	Gear	Gear		1
163	Gear	Gear		1
164	Snap Ring	Snap Ring	24	1
165	Spacer	Spacer		1
166	Gear	Gear		1
167	Bearing	Bearing	2512	4
168	Spacer	Spacer		1
169	Snap Ring	Snap Ring	24	1
170	Gear	Gear		1
171	Spacer	Spacer		1
172	Ball Bearing	Ball Bearing	80204	1
173	Screw	Screw	M6×12	1
174	Washer	Washer		1
175	Shaft	Shaft		1
176	O-Ring	O-Ring	35×3.1	1
177	Spacer	Spacer		1
178	Stalk Set	Stalk Set		1
179	Gear	Gear	42T×M2	1
180	Spacer	Spacer		1
181	Snap Ring	Snap Ring	30	1
182	Oil Seal	Oil Seal	TC47×25×8	1
183	Ball Bearing	Ball Bearing	80105	1
184	Screw	Screw	M6×20	3
185	Bearing Flanged	Bearing Flanged		1
186	Sealed Mat	Sealed Mat		1
187	Ball Bearing	Ball Bearing	80205	1
188	Key	Key	6×28	1
189	D Shaft	D Shaft		1
190	Key	Key	6×60	1
191	Spacer	Spacer		1
192	Gear	Gear		1
193	Spacer	Spacer		1
194	Snap Ring	Snap Ring	25	1
195	Gear	Gear		1
196	Key	Key	6×18	1
197	Gear	Gear		1
198	Snap Ring	Snap Ring	40	1
199	Ball Bearing	Ball Bearing	80204	1

**CL-460 HEADSTOCK PARTS**

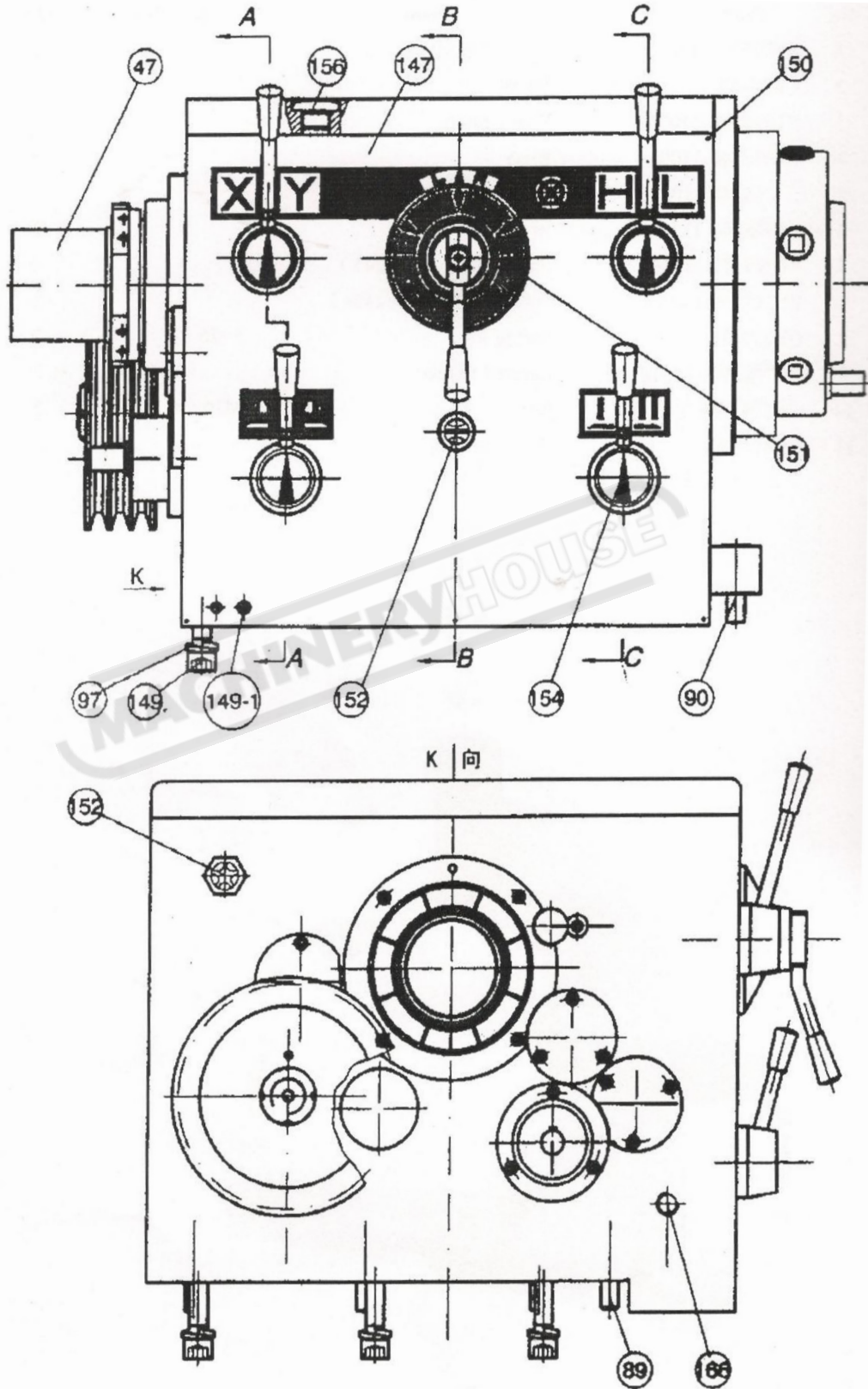

**CL-460 HEADSTOCK PARTS Cont.**

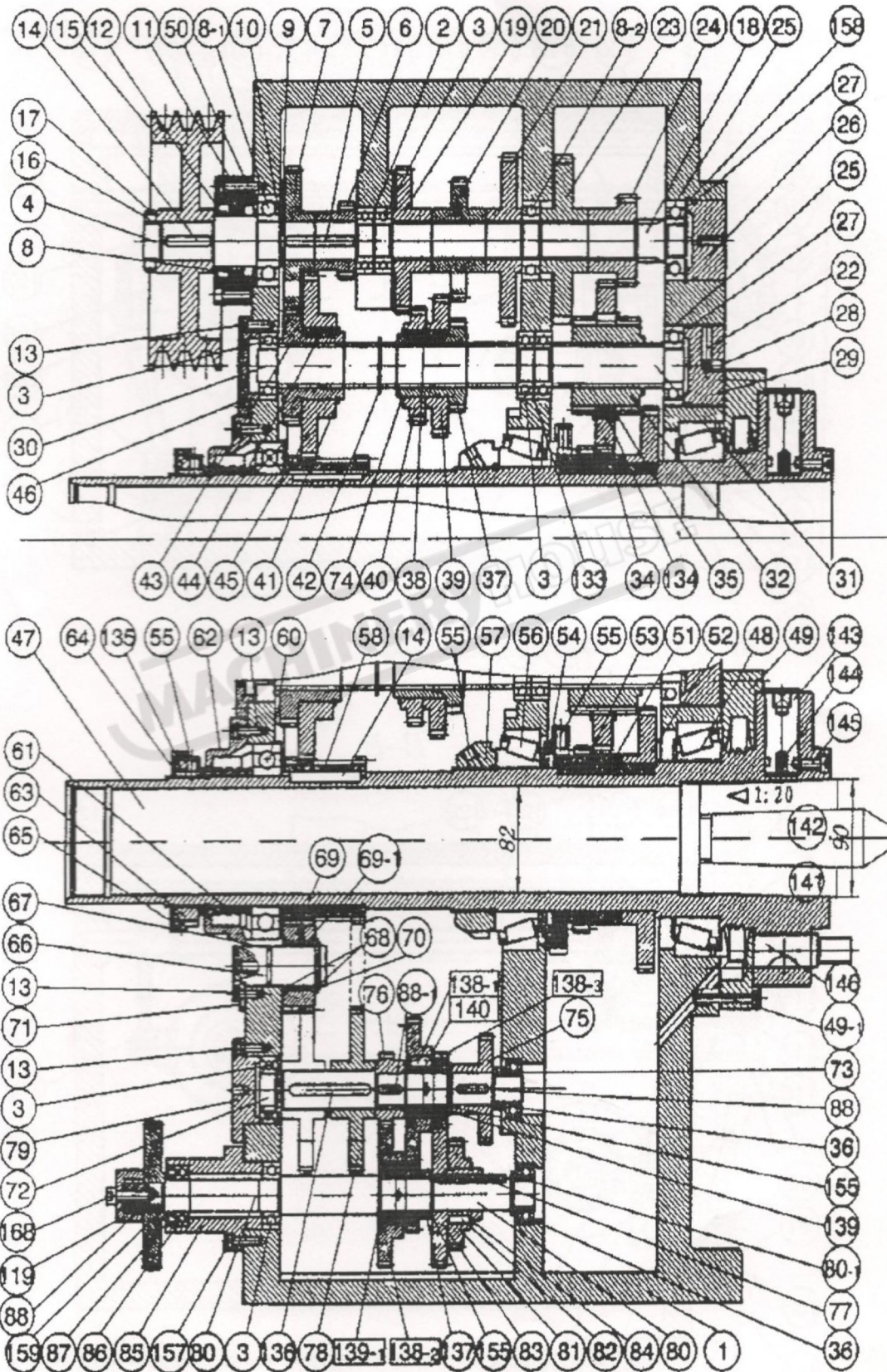

**CL-460 HEADSTOCK PARTS Cont.**

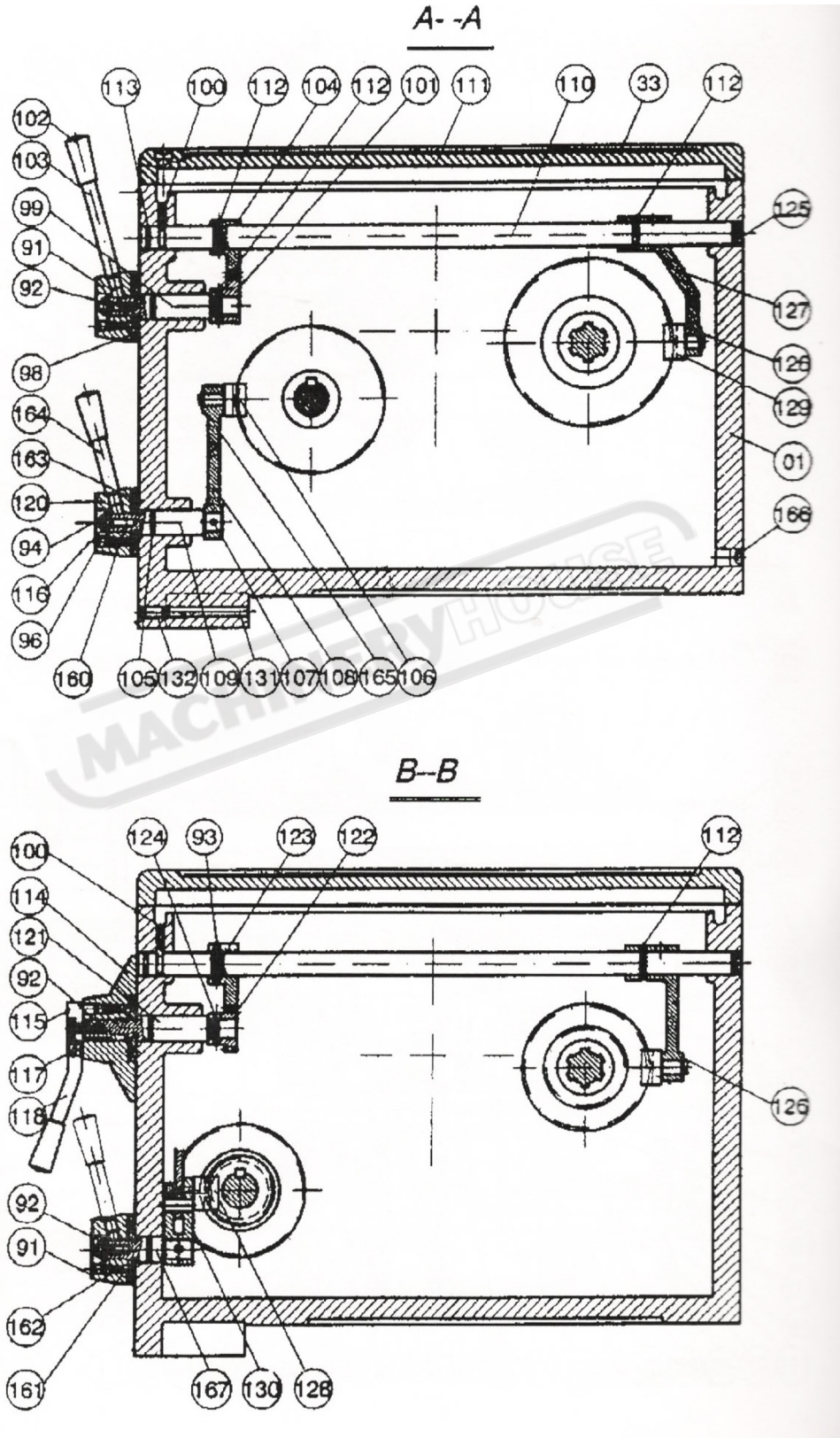

**CL-460 HEADSTOCK PARTS Cont.**

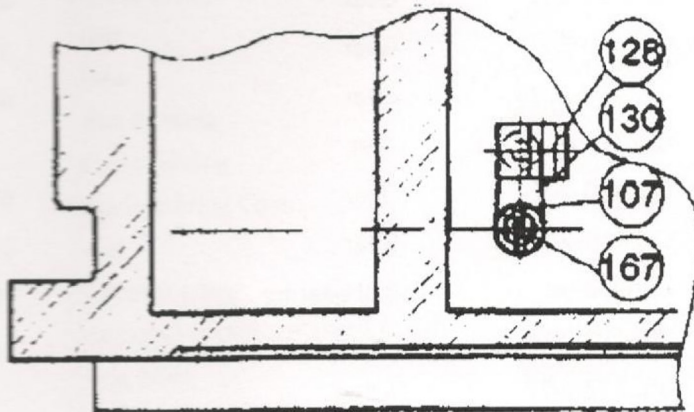
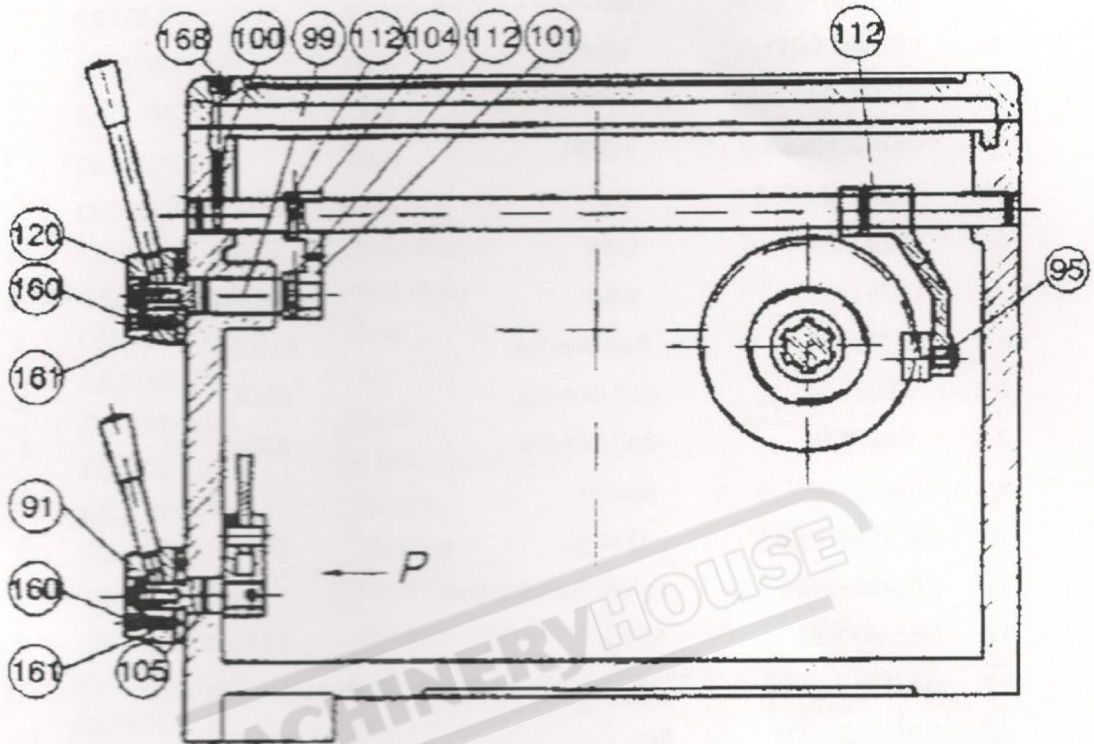

**OPERATION MANUAL**

**CL-460 HEADSTOCK PARTS LIST**

No	Part No.	Item	Specification	Qty.
1	C6241D/46-2001	Headstock Carsting		1
2	C6241D-2011	Spacer		1
3	GB276-94	Ball Bearing	6205	7
4	C6241D-2004	I shaft		1
5	GB/1096-2003	Key	8x7x60	1
6	C6241-2010	Gear	20TXM2.75	1
7	C6241-2009	Gear	40TXM2.75	1
8	GB276-94	Ball Bearing	61908	1
8-1	GB276-94	Ball Bearing	6306	1
8-2	GB276-94	Ball Bearing	6206	1
9	C6241D-2004-1	Spacer		1
10	GB/T894.1-86	O-ring	30	1
11	C6241D-2006	I shaft flange cover		1
12	GB13871-92	Spacer	FB40X62X12	1
13	GB/T70.1-2000	Hex. cap screws	M6X16	11
14	GB/1096-2003	Key	8X7X45	1
15	C6241-2005	Pulley		1
16	GB/T 812-88	Nut	M30X1.5	1
17	GB/T 858-88	Toothed lock washer	30	1
18	C6241D-2020	III shaft		1
19	C6241D-2021	Gear	40TXM2.75	1
20	C6241D-2022	Gear	33TXM2.75	1
21	C6241D-2023	Gear	47TXM2.75	1
22	C6241-2032	Pin		1
23	C6241D-2024	Gear	46TXM2.75	1
24	C6241D-2025	Gear	24TXM2.75	1
25	GB276-94	Ball Bearing	6305	1
26	C6241D-2026	Plug		1
27	GB3452.1-92	O-ring	58X2.65	2
28	GB/T78-2000	Hex socket set screws	M8X10	1
29	C6241D-2031	Plug		1
30	C6241D-2014	II Shaft		1
31	C6241D-2028	IV Shaft		1
32	C6241D-2029	Gear	25TXM2.75	1
33	C6241D-2002-1	Spacer		1
34	C6241D-2030	Gear	47TXM2.75	1
35	GB/T894.1-86	Snap Ring	68	1
36	GB276-94	Ball Bearing	6204	1
37	C6241D-2019	Gear	24TXM2.75	1
38	GB/1096-2003	Key	8X7X35	1
39	C6241D-2018	Gear	38TXM2.75	1

**OPERATION MANUAL**

**CL-460 HEADSTOCK PARTS LIST Cont.**

No	Part No.	Item	Specification	Qty.
40	C6241-2017	Gear	31TXM2.75	1
41	GB/T894.1-86	Snap Ring	52	1
42	GB/T894.1-86	Snap Ring	34	1
43	C6241D-2015	Gear	31TXM2.75	1
44	GB/1096-2003	Key	8X7X25	1
45	C6241D-2016	Gear	51TXM2.75	1
46	C6241D-2012	II Shaft cover		1
47	C6241D-2033	Spindle	D6M6	1
48	GB/T297-94	Bearing	32024/P5	1
49	C6241D-2035	Front Bearing Cover		1
49-1	GB/T70.1-2000	Socket head cap screws	M6X40	5
50	GB/T70.1-2000	Socket head cap screws	M6X35	4
51	GB/1096-2003	key	10X8X85	1
52	C6241D-2037	Gear	72TXM2.75	1
53	C6241D-2038	Gear	50TXM2.75	1
54	C6241D-2039	Null		1
55	GB/T77-2000	Socket set screws Flat pt	M10X10	5
56	GB/T297-94	TAPERED Roller bearing	32022/P5	1
57	C6241D-2040	Nut		1
58	C6241D-2041	Gear	55TXM2.25	1
60	GB276-94	Ball Bearing	6020/P5	1
61	C6241D-2043	Cycle oil ring		1
62	C6241D-2044	Back Bearing Cover		1
63	C6241D-2046	Nut		1
64	C6241D-2047	Balance piece		1
65	GB/T79-2000	Socket set screws point	M6X8	4
66	6241D-2048	Shaft		1
67	GB3452.1-92	O-ring	30X2.65	1
68	C6241D-2050	Spacer		2
69	C6241D-2049	Gear	30TXM2.25	1
69-1	C6241D-2049-1	Cover		1
70	GB/T894.1-86	Snap Ring	30	1
71	C6241D-2051	Washer		1
72	C6241D-2054	C-shaft		1
73	C6241D-2060	Spacer		1
74	GB/T894.1-86	Snap Ring	48	1
75	C6241D-2059	Gear	36TXM2.25	1
76	C6241D-2056	Gear	24TXM2.25	1
77	GB/1096-2003	Key	6X6X60	1
78	C6241D-2055	Gear	55TXM2.25	1
79	C6241D-2052	Cover		1

**CL-460 HEADSTOCK PARTS LIST Cont.**

No	Part No.	Item	Specification	Qty.
80	C6241D-2066	D-shaft		1
80-1	GB/1096-2003	Key	6X6X70	1
81	C6241D-2062	Gear	36TXM2.25	1
82	GB/1096-2003	Key	6X6X18	1
83	C6241D-2061	Gear	48TXM2.25	1
84	GB/T894.1-86	Snap Ring	40	1
85	C6241D-2065	D-shaft cover		1
86	GB276-94	Ball Bearing	6005	1
87	GB13871-92	Skeleton oil seal	FB25X47X7	1
88	GB/1096-2003	Key	6X6X28	2
88-1	GB/1096-2003	Key	6X6X20	1
89	GB/T120-2000	Pin (410)	16X55	1
89	GB/T120-2000	Pin (460)	16X80	1
90	GB/T70.1--2000	Socket head cap Screws(410)	M16X45	3
90	GB/T70.1--2000	Socket head cap Screws(460)	M16X70	3
91	C6241D-2077	Level hand		3
92	GB/1096-2003	Key	5X5X12	5
93	GB/T879.2-2000	Pin	5X35	3
94	C6241D-2078	Washer		4
95	C6241D-2071	Fork		1
96	GB/T77--2000	Socket set screws- Flat point	M8x8	6
97	GB/T93-87	Spring Spacer	16	3
98	C6241D-2076	Fix Black		5
99	C6241D-2075	Shaft		2
100	GB/T79--2000	Socket set screws-Dog point	M6X14	3
101	C6241-2074	Gear	29TXM2	2
102	JB/7271.3-94	Knob	BM10X40	5
103	JB/7271.6-94	Handle	BM10X63	2
104	C6241-2073	Gear	29TXM2	2
105	GB3452.1-92	O-ring	17X2.65	5
106	C6241D-2088	Fork		1
107	GB/T879.2-2000	Pin	4X30	2
108	C6241D-2089	Lever		1
109	C6241D-2090	Shaft		1
110	C6241D-2068	Shaft		3
111	C6241D-2002	Headstock cover		1
112	GB/T879.2-2000	Pin	5X30	7
113	GB3452.1-92	O-ring	15X2.65	3

**OPERATION MANUAL**

**CL-460 HEADSTOCK PARTS LIST Cont.**

No	Part No.	Item	Specification	Qty.
114	C6241-2083	Handle		1
115	C6241-2084	Fix Bracket		1
116	C6241-4048	Screw	M8X20	5
117	GB/T879.2-2000	Pin	4X20	1
118	C6241-2085	Lever		1
119	C6241-2067	Cover		1
120	C6241-2092	Handle		1
121	C6241-2082	Shaft		1
122	C6241-2081	Gear	16TXM2	1
123	C6241-2080	Gear	44TXM2	1
124	GB/T879.2-2000	Pin	5X25	1
125	C6241-2069	Plug		3
126	GB/T894.1-86	Snap Ring	12	3
127	C6241D-2070	Lever		3
128	C6241D-2095	Fork		1
129	C6241D-2072	Fork		2
130	C6241D-2093	Lever		1
131	C6241-2098	Pin		1
132	GB/T79--2000	Socket set screw-Dog point	M10X20	1
133	C6241D-2027	Spacer		1
134	C6241D-2097	Pin	A7X10X17	2
135	C6241D-2046-1	Brass		1
136	GB/1096-2003	Key	8X7X70	1
137	C6241D-2063	Spacer		1
138-1	GB/1096-2003	Key	10X8X18	2
138-2	C6241D-2057-2	Gear	48TXM2.25	2
138-3	C6241D-2057-3	Gear	24TXM2.25	2
139	C6241-2058	Spacer		1
139-1	C6241-2058-1	Spacer		2
140	GB12613.1-2002	Cover	25X28X12	4
141	JB/T9940.1-99	Cover	R5490X4	1
142	GB/T9204-2008	Center	DG4	1
143	C6260-2034	CAM LOCK		6
144	GB/T2089-94	Spring	1.2X7X25	6
145	C6260-2033-1	Screw	M8X20	6
146	C6260-2099	CAM LEVER		6
147	C6241D-2087	Plate		1
149-1	GB/T70.1-2000	Socket head cap screws	M10X90	1
149	GB/T70.1-2000	Socket head cap screws	M16X55	3
150	GB/T70.1-2000	Socket head cap screws	M3X6	6

**OPERATION MANUAL**

**CL-460 HEADSTOCK PARTS LIST Cont.**

<b>No</b>	<b>Part No.</b>	<b>Item</b>	<b>Specification</b>	<b>Qty.</b>
151	C6241-2086	Plate		1
152	JB/T7941.1	Oil lever	A20	1
153				
154	C6241-2079	Plate		4
155	GB/T894.1-86	Snap Ring	25	3
156	C6241-3100	Cover		1
157	GB/T70.1-2000	Socket head cap screws	M6X20	3
158	GB/T893.1-86	Snap Ring	62	1
159	C6241-2013	Gear	55TXM2.5	1
160	GB/T80--2000	Socket set screw-cup point	M5X25	5
161	GB308-89	Steel Ball	φ6	6
162	GB/T2089-94	Spring	1X5X25	6
163	GB/T68-2000	Slotted c/sunk head bolt	M6X12	10
164	JB/7271.3-94	Lever	BM10X25	2
165	GB/T894.1-86	Circlips for shaft-Type	10	2
166	JB/ZQ4447-97	Nut	NPT3/8"X19	1
167	C6241D-2090	Shaft		1
168	GB/T70.1-2000	Socket head cap screws	M8X20	5

**GEARBOX PARTS**

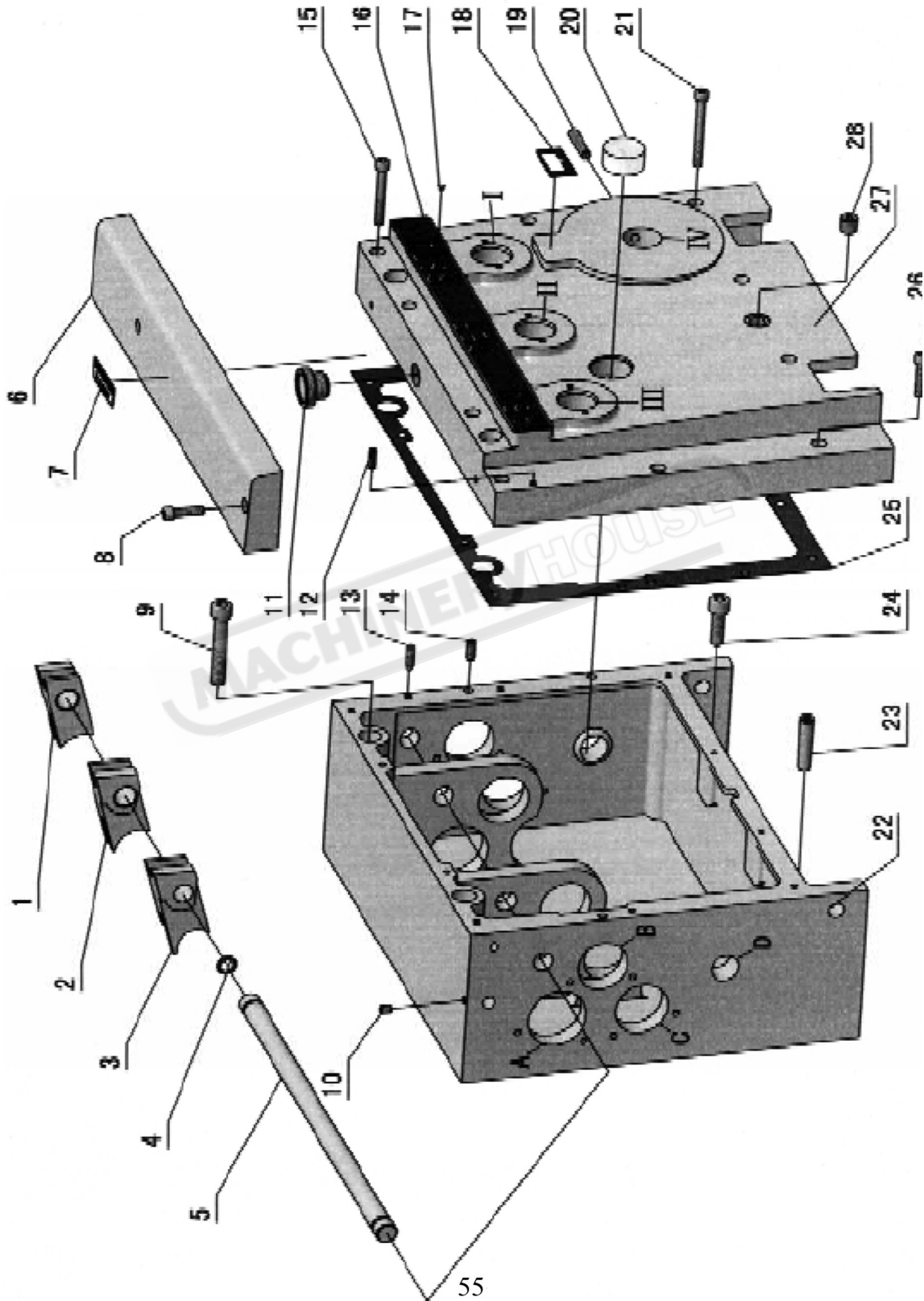

**GEARBOX PARTS Cont.**

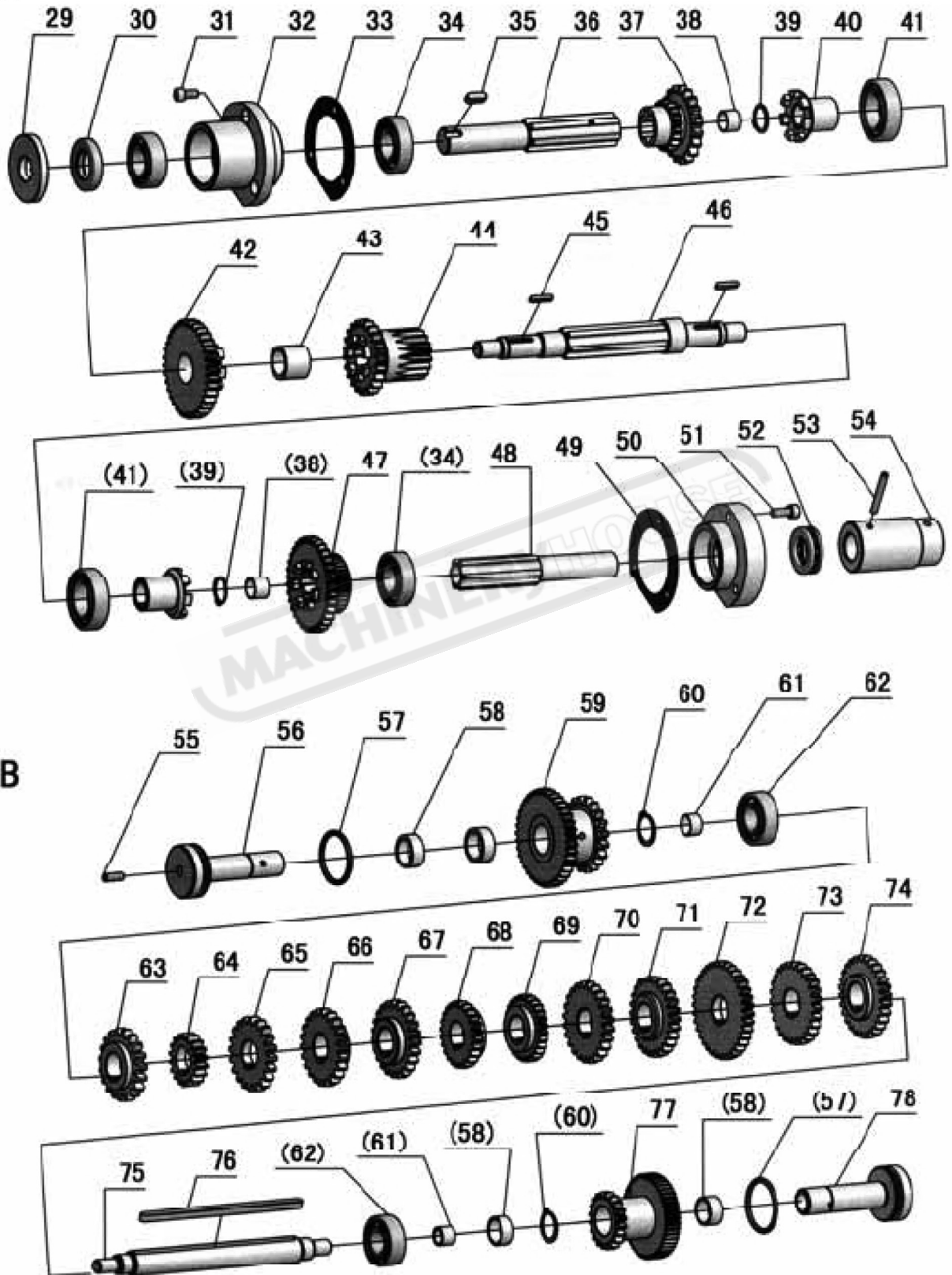

**GEARBOX PARTS Cont.**

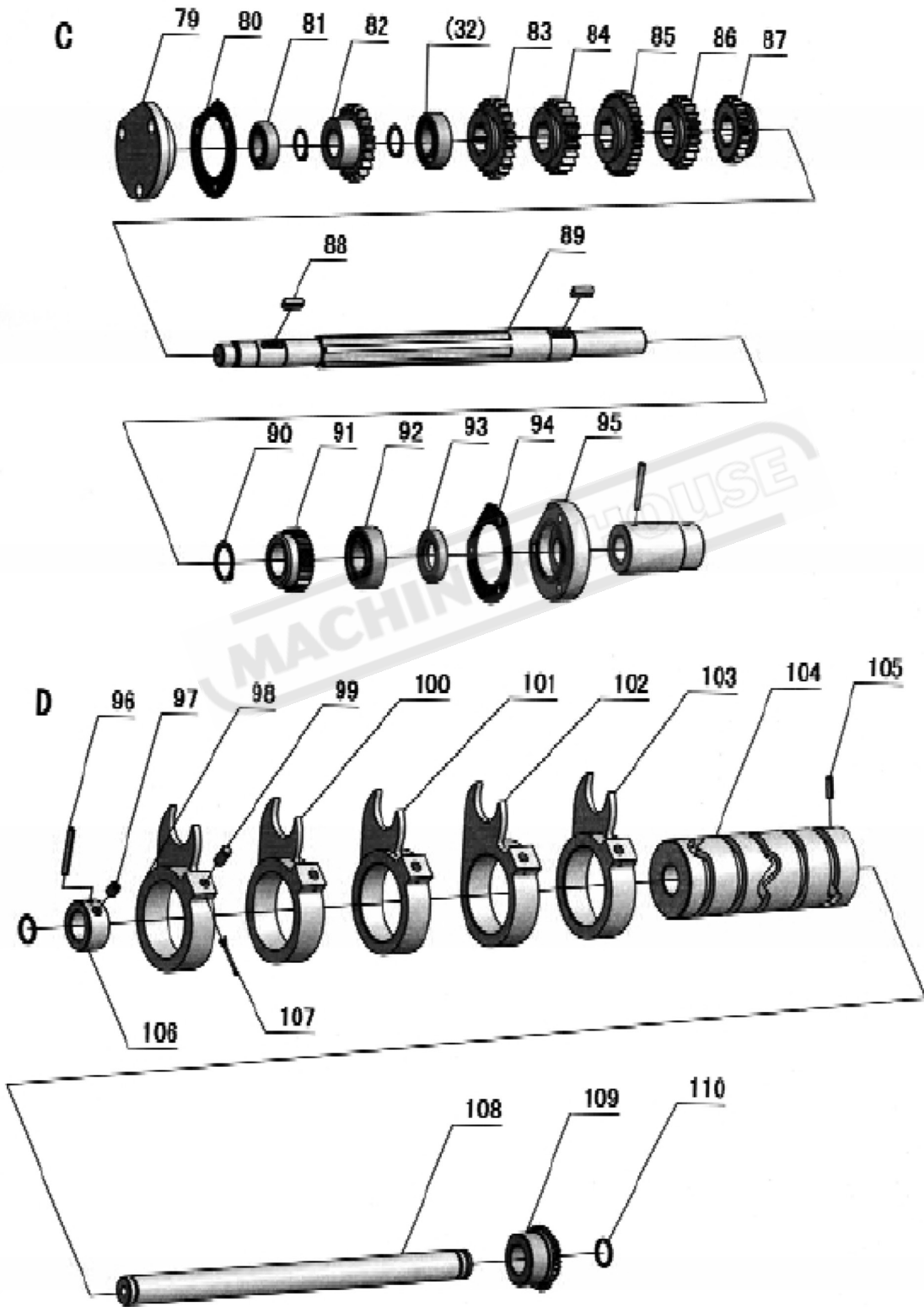

**GEARBOX PARTS Cont.**

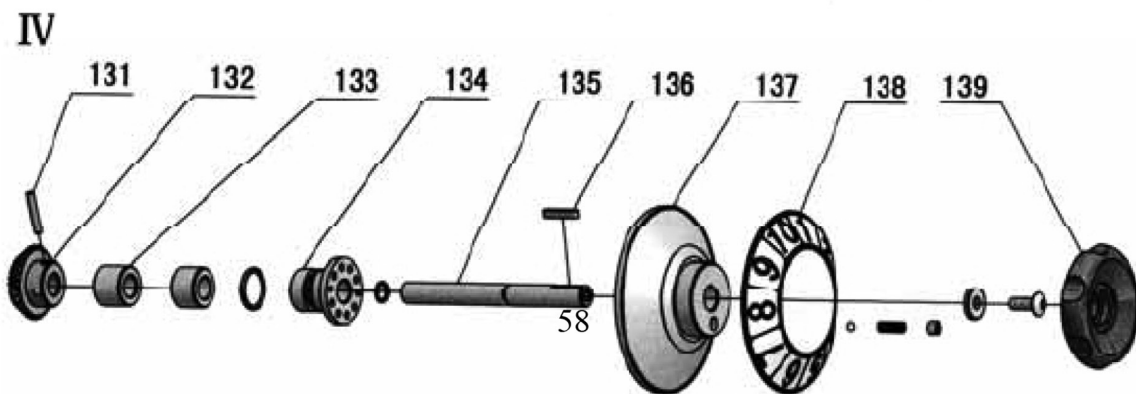
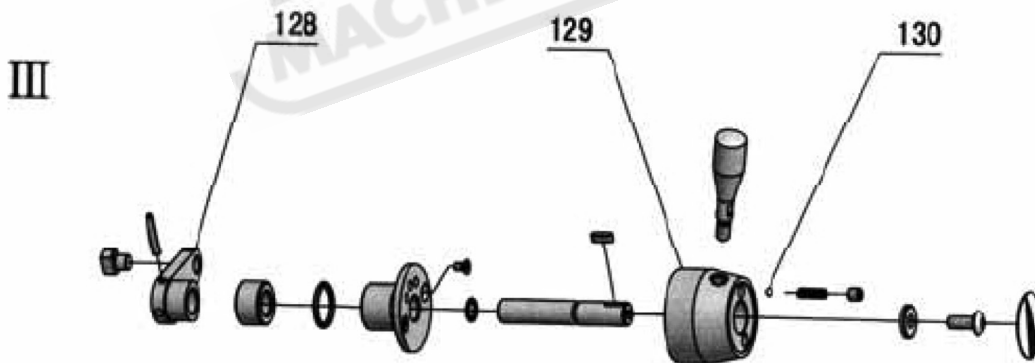
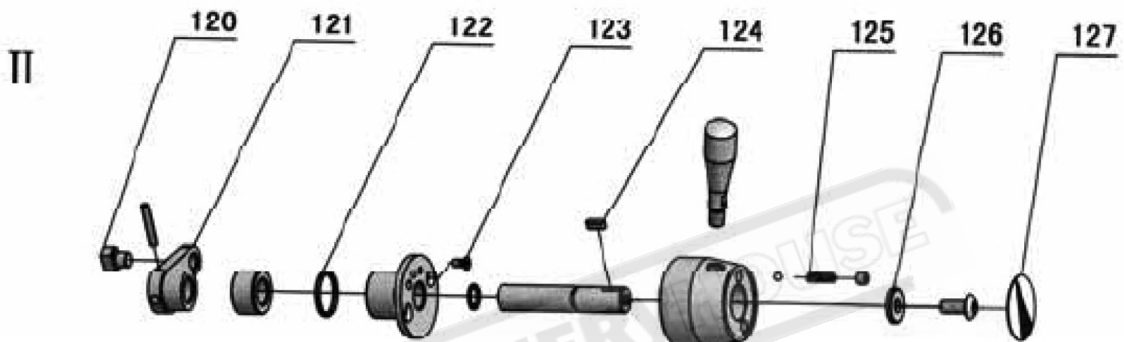
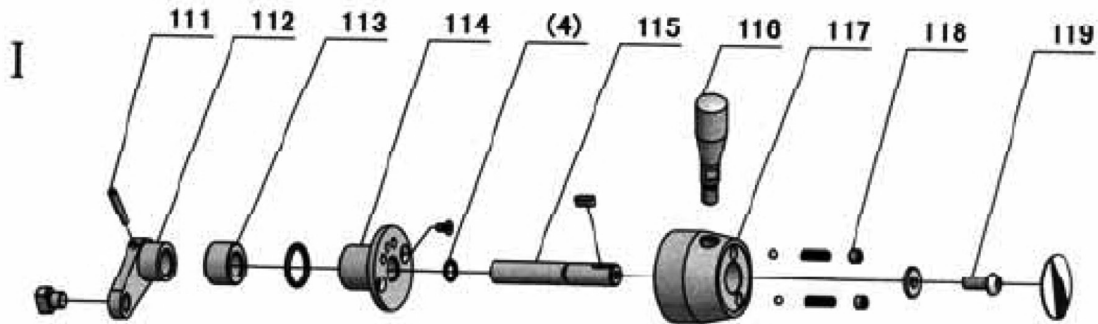

**GEARBOX PARTS LIST**

No	Part No.	Item	Specification	Qty.
1	RUN6141-102070-1	Fork		1
2	RUN6246-102069	Fork		1
3	RUN6246-102069-1	Fork		1
4	GB1235-76	O-Ring	16×2.4	6
5	RUN6246-102077	Shaft		1
6	RUN6141-102061	Top Cover		1
7	RUN6246-102079	Plate		1
8	GB70-85	Screw	M6×30	2
9	GB70-85	Screw	M10×60	2
10	GB78-85	Screw	M6×8	1
11	RUN6246-103031	Oil Cover		1
12	GB879-86	Spring Pin	5×16	2
13	GB79-85	Socket Set Screw	M6×20	2
14	GB78-85	Screw	M6×16	2
15	GB70-85	Screw	M6×50	1
16	RUN6246-102080	Plate		1
17	GB827-86	Rivet	2×5	10
18	RUN6246-102081	Plate		1
19	GB78-85	Screw	M8×35	1
20	GB1160.1-89	Oil Sight Glass	20	1
21	GB70-85	Screw	M6×60	3
22	RUN6246-102001A	Gear Box		1
23	GB118-86	Taper Pin	10×45	2
24	GB70-85	Screw	M10×30	2
25	RUN6246-102001-2A	Sealed Mat		1
26	GB70-85	Screw	M6×30	3
27	RUN6141-102002A	Front Cover		1
28	G38-3A	Oil Plug	Z 3/8"	1
29	RUN6246-102052	Spacer		1
30		Oil-Seal	TC20×42×8	1
31	GB70-85	Socket Head Cap Screw	M6×12	6
32	RUN6246-102050	Cap		1
33	RUN6246-102050-1	Sealed Mat		1
34	GB278-89	Ball Bearing	80104	4
35	GB1096-79	Key	6×10	1
36	RUN6246-102049	B-Shaft		1
37	RUN6246-102048	Gear		1
38	SF-1	Ball Bearing	1410	2
39	GB894.1-86	Snap Ring	18	2
40	RUN6246-102047	Clutch		2

**OPERATION MANUAL**

**GEARBOX PARTS LIST Cont.**

No	Part No.	Item	Specification	Qty.
41	GB278-89	Ball Bearing	80105	2
42	RUN6246-102046	Gear		1
43	SF-1	Ball Bearing	2020	1
44	RUN6246-102045	Gear		1
45	GB1096-79	Key	4x20	2
46	RUN6246-102044	A-Shaft		1
47	RUN6141-102042-1	Gear		1
48	RUN6246-102041	C-Shaft		1
49	RUN6246-102040-1	Sealed Mat		1
50	RUN6246-102040	Cap		1
51	GB70-85	Socket Cap Screw	M6x20	6
52	GB301-84	Thrust Bearing	8104	1
53	GB879-86	Spring Pin	5x35	2
54	RUN6246-102012	Collar-Linkage		2
55	GB78-85	Screw	M6x16	2
56	RUN6246-102023	E-Shaft		1
57	GB3452.1-82	O-Ring	35.5x3.55	2
58	SF-1	Ball Bearing	2012	4
59	RUN6246-102024	Gear		1
60	GB894.1-86	Snap Ring	20	4
61	SF-1	Ball Bearing	1218	2
62	RUN6246-102026	Gear		1
63	RUN6246-102027	Gear		1
64	RUN6246-102028	Gear		1
65	RUN6246-102029	Gear		1
66	RUN6246-102030	Gear		1
67	RUN6246-102031	Gear		1
68	RUN6246-102032	Gear		1
69	RUN6246-102033	Gear		1
70	RUN6246-102034	Gear		1
71	RUN6246-102035	Gear		1
72	RUN6246-102036	Gear		1
73	RUN6246-102037	Gear		1
74	RUN6246-102025	D-Shaft		1
75	GB1096-79	Key	6x146	1
76	GB278-89	Ball Bearing	80203	2
77	RUN6141-102038	Gear		1
78	RUN6246-102039	F-Shaft		1
79	RUN6246-102022	Cap		1
80	RUN6246-102022-1	Sealed Mat		1

**GEARBOX PARTS LIST Cont.**

No	Part No.	Item	Specification	Qty.
81	GB278-89	Ball Bearing	80103	1
82	RUN6246-102020	Gear		1
83	RUN6246-102019	Gear		1
84	RUN6246-102018	Gear		1
85	RUN6246-102017	Gear		1
86	RUN6246-102016	Gear		1
87	RUN6246-102015	Gear		1
88	GB1096-79	Key	6×20	2
89	RUN6246-102021	G-Shaft		1
90	GB894.1-86	Snap Ring	25	1
91	RUN6141-102014-1	Gear		1
92	GB278-89	Ball Bearing	80204	1
93		Oil Seal	TC20×40×7	1
94	RUN6246-102013-1	Sealed Mat		1
95	RUN6246-102013	Cap-Right		1
96	GB879-86	Spring Pin	5×35	1
97	GB78-85	Socket Set Screw	M8×10	1
98	RUN6246-102008	Claw-Shifter		1
99	GB119-86	Pin	B8×16	5
100	RUN6246-102007	Claw-Shifter		1
101	RUN6246-102006	Claw-Shifter		1
102	RUN6246-102005	Claw-Shifter		1
103	RUN6246-102004	Claw-Shifter		1
104	RUN6246-102009	Cam Shifter		1
105	GB879-86	Spring Pin	5×16	2
106	RUN6246-102010	H-Shaft		1
107	GB91-86	Split Pin	2×30	5
108	RUN6246-102011	H-Shaft		1
109	RUN6246-102003	Bevel Gear		1
110	GB1235-76	O-Ring	22×2.4	2
111	GB879-86	Spring Pin	5×30	3
112	RUN6246-102066	Arm		1
113	RUN6141-102062-2	Spacer		4
114	RUN6246-102075	Detent Plate		3
115	RUN6141-102072	Shaft		3
116	RUN6246-102056-1	Lever		3
117	RUN6246-102076	Speed Change Handle		1
118	GB77-85	Screw	M8×8	5
119	RUN6246-101088	Screw		4
120	RUN6246-102073	Fork		3

**GEARBOX PARTS LIST Cont.**

<b>No</b>	<b>Part No.</b>	<b>Item</b>	<b>Specification</b>	<b>Qty.</b>
121	RUN6246-102067	Arm		1
122	GB1235-76	O-Ring	30×3.1	4
123	GB819-85	Screw	M5×10	6
124	GB1096-79	Key	5×14	3
125	RUN6246-101066	Spring		5
126	RUN6246-101070-1	Washer		4
127	RUN6246-101099	Plate		3
128	RUN6246-102068	Arm		1
129	RUN6246-102065	Speed Change Handle		2
130	GB308-77	Steel Ball	1/4"	5
131	GB879-76	Spring Pin	5×30	1
132	RUN6246-102060	Bevel Gear		1
133	RUN6246-102062-1	Spacer		1
134	RUN6246-102062	Shaft Sleeve		1
135	RUN6141-102055	Shaft		1
136	GB1096-79	Key	5×28	1
137	RUN6246-102063	Selecting Dial		1
138	RUN6246-102082	Plate		1
139	RUN6246-102053	Wheel		1

**SADDLE PARTS**

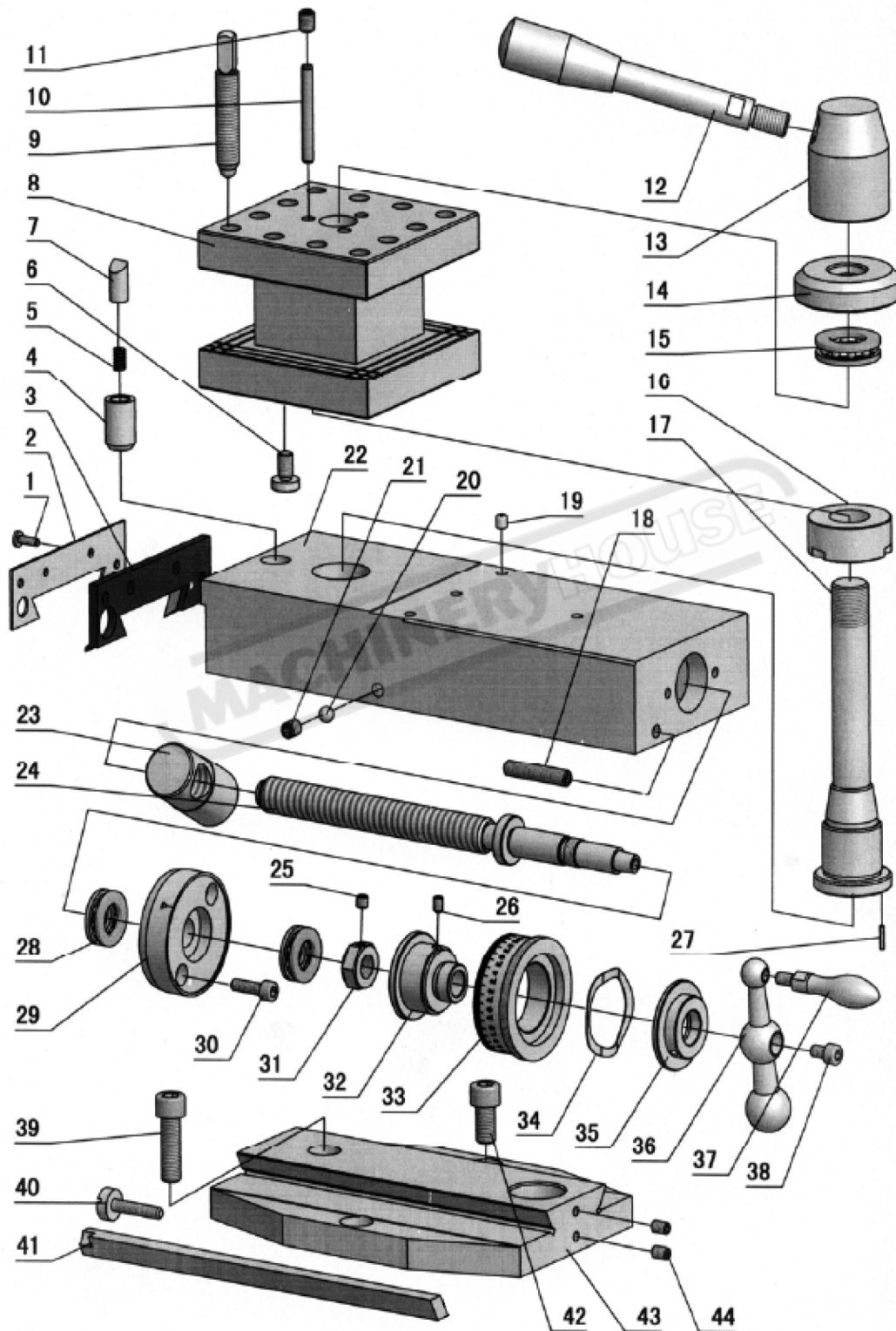

**SADDLE PARTS Cont.**

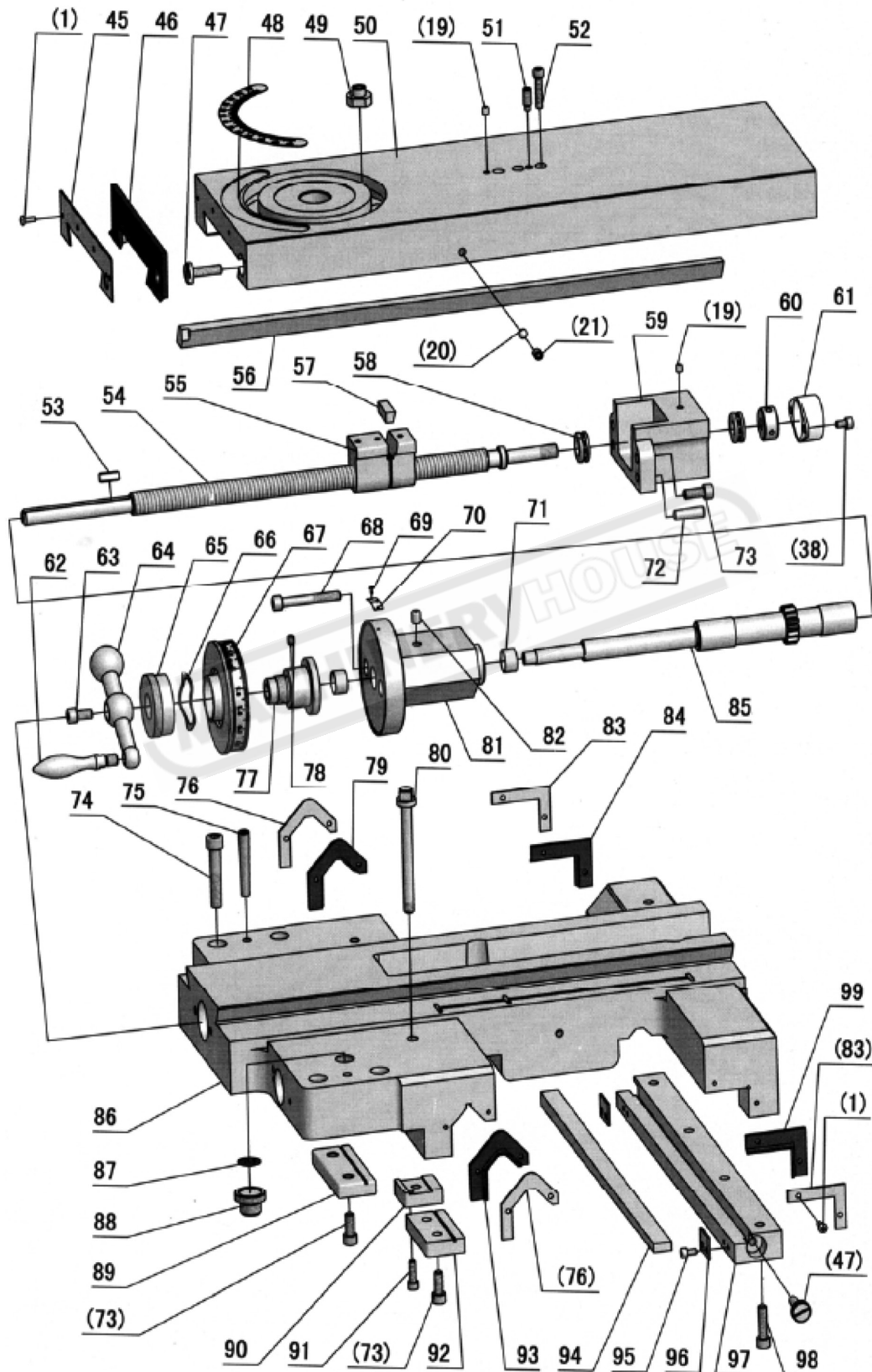

**SADDLE PARTS Cont.**

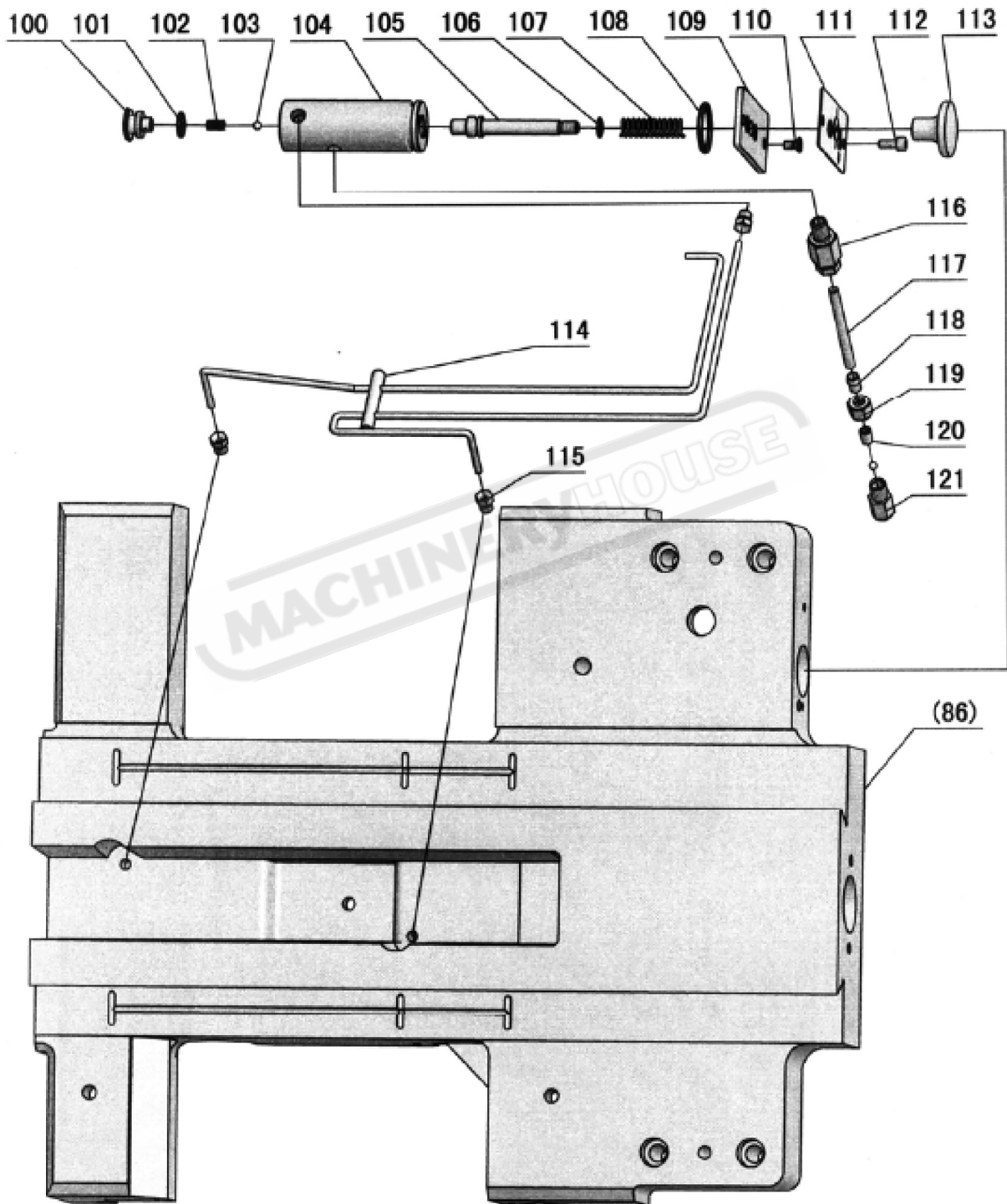

**OPERATION MANUAL**

**SADDLE PARTS LIST Cont.**

No	Part No.	Item	Specification	Qty.
1	GB818-85	Screw	M4×12	16
2	RUN6141-103101	Case-Wiper		1
3	RUN6141-103100	Wiper		1
4	RUN6246-103056-1	Sleeve		1
5	GB2089-80	Spring	1×5×18	1
6	RUN6246-103058-2	Adjust Screw (Flat Type)		3
7	RUN6246-103057-2	Round Pin		1
8	RUN6141-103058	Four Way Tool Post (Flat Type)		1
8	RUN6141-103058-3	Four Way Tool Post (T Type)		1
8	RUN6141-103058-4	Block-Tee (T Type)		1
9	GB83-88	Screw	M12×55	12
10	GB119-86	Pin	D6×50	3
11	GB77-85	Screw	M8×10	3
12	RUN6246-103062	Clamping Handle		1
13	RUN6246-103061	Clamping Handle		1
14	RUN6246-103060	Washer		1
15	GB301-84	Thrust Bearing	8104	1
16	RUN6246-103058-1	Sleeve (Flat Type)		1
17	RUN6141-103054	Tool Post Shaft (Flat Type)		1
17	RUN6141-103054-1	Tool Post Shaft (T Type)		1
18	GB77-85	Screw	M8×40	1
19	GB1155-79	Ball Cup	6	6
20	GB308-84	Steel Ball	1/4"	2
21	GB80-85	Screw	M8×10	2
22	RUN6141-103050	Compound Rest (Flat Type)		1
22	RUN6141-103050-2	Compound Rest (T Type)		1
23	RUN6246-103043-1	Nut (Run6141 Metric)		1
23	RUN6246-103043-2	Nut (Run6141 Inch)		1
23	RUN6246H-103043-1	Nut (Run6246h Metric)		1
23	RUN6246H-103043-2	Nut (Run6246h Inch)		1
24	RUN6246-103043	Screw-Compound Rest (Metric)		1
24	RUN6246-103043-3	Screw-Compound Rest (Inch)		1
25	GB77-85	Screw	M6×6	1
26	GB80-85	Screw	M5×8	1
27	GB879-86	Spring Pin	2×12	1
28	GB301-84	Thrust Bearing	8102	2
29	RUN6246-103044	Seat Compound Rest Screw		1
30	GB70-85	Screw	M6×20	2
31	RUN6246-103044-1	Nut		1
32	RUN6246-103045	Collar		1

**SADDLE PARTS LIST Cont.**

No	Part No.	Item	Specification	Qty.
33	RUN6246-103046-1	Dial-Compound Rest (Metric)		1
33	RUN6246-103046-2	Dial-Compound Rest (Inch)		1
34	RUN6246-103047-1	Wave Type Washer		1
35	RUN6246-103047	Nut		1
36	RUN6246-103048	Handle		1
37	RUN6246-103049	Handle		1
38	GB70-85	Screw	M6×10	3
39	GB70-85	Screw(C6241)	M10×35	1
39	GB70-85	Screw(C6246H)	M10×60	1
40	RUN6246-103037	Screw		1
41	RUN6141-103051	Gib		1
42	GB70-85	Screw(C6241)	M10×20	2
42	GB70-85	Screw(C6246H)	M10×35	2
43	RUN6141-103041	Swivel Table		1
43	RUN6246H-103041	Swivel Table		1
44	GB80-85	Screw	M6×10	2
45	RUN6141-103039	Case-Wiper		1
46	RUN6141-103038	Wiper		1
47	RUN6246-103036	Screw		4
48	RUN6141-103002-1	Indicator Dial		1
49	RUN6246-103040	Nut		3
50	RUN6141-103002	Cover-Cross Sliding		1
51	GB79-85	Screw	M8×20	1
52	GB70-85	Screw	M6×30	3
53	RUN6246-103022-2	Key		1
54	RUN6141-103021	Cross Feed Screw (Inch)		1
54	RUN6141-103021-1	Cross Feed Screw (Metric)		1
55	RUN6141-103003	Nut (Metric)		1
55	RUN6141-103003-1	Nut (Inch)		1
56	RUN6141-103035	Gib		1
57	RUN6246-103004	Gib		1
58	GB301-84	Thrust Bearing	8101	2
59	RUN6141-103007	Bracket		1
60	RUN6246-103007-1	Nut		1
61	RUN6141-103105	Cover		1
62	RUN6246-103030A	Handle		1
63	GB70-85	Screw	M8×16	1
64	RUN6246-103029	Handle		1
65	RUN6246-103028	Nut		1
66	RUN6246-103025	Wave Type Washer		1

**SADDLE PARTS LIST Cont.**

No	Part No.	Item	Specification	Qty.
67	RUN6141-103027	Cross Feed Dial (Metric)		1
67	RUN6141-103027-1	Cross Feed Dial (Inch)		1
68	GB70-85	Screw	M8×60	2
69	GB278-86	Screw	2×5	2
70	RUN460-105031	Plate		1
71	SF-1	Bearing	1810	2
72	GB118-86	Taper Pin	6×26	2
73	GB70-85	Screw	M8×20	6
74	GB70-85	Screw	M10×55	4
75	GB118-86	Taper Pin	8×60	2
76	RUN6141-103013	Case-Wiper		2
77	RUN6246-103026	Clutch-Dial		1
78	GB80-85	Screw	M6×8	1
79	RUN6141-103011	Wiper		1
80	RUN6246-103077	Bolt		1
81	RUN6246-103023	Bracket		1
82	GB1155-79	Ball Cup	8	1
83	RUN6141-103010	Case-Wiper		2
84	RUN6141-103008	Wiper		1
85	RUN6246-103022	Cross Feed Pinion		1
86	RUN6141-103001	Saddle		1
87	RUN6246-103031-1	Plate		1
88	RUN6246-103031	Plug-Oil Inlet		1
89	RUN6141-103020	Gib-Front		1
90	RUN6246-103019	Clamp-Carriage		1
91	GB70-85	Screw	M6×20	1
92	RUN6141-103018	Gib-Left-Front		1
93	RUN6141-103012	Wiper		1
94	RUN6141-103015	Gib		1
95	GB70-85	Screw	M5×10	4
96	RUN6141-103016-1	Baffle		2
97	RUN6141-103016	Holder Gib		1
98	GB70-85	Screw	M8×30	4
99	RUN6141-103009	Wiper		1
100	RUN6246-103070	Oil Plug		1
101	GB1235-76	O-Ring	16×2.4	1
102	GB2089-80	Spring	0.5×4.5×16	1
103	GB308-84	Steel Ball	φ5	2
104	RUN6246-103063	Body Pump		1
105	RUN6246-103064	Piston Rod		1

**SADDLE PARTS LIST Cont.**

No	Part No.	Item	Specification	Qty.
106	GB3452.1-82	O-Ring	9×1.8	1
107	RUN6246-103065	Spring		1
108	GB1235-76	O-Ring	32×3.1	1
109	RUN6246-103066	Bottom Board		1
110	GB68-85	Screw	M5×10	2
111	RUN6246-103068	Plate		1
112	GB70-85	Screw	M5×12	2
113	RUN6246-103067	Plug		1
114	RUN6141-103106	Vitta welding		1
115		Tube Fitting	Z 1/8"×φ4	3
116		Tube Fitting	Z 1/8"×φ6	1
117		Brass Tube	φ6×170	1
118	RUN6246-103071	Tube Fitting		1
119	RUN6246-103072	Nut		1
120	RUN6246-103073-2	Sleeve		1
121	RUN6246-103073-1	One Way Valve Ass		1

MACHINERYHOUSE

APRON PARTS

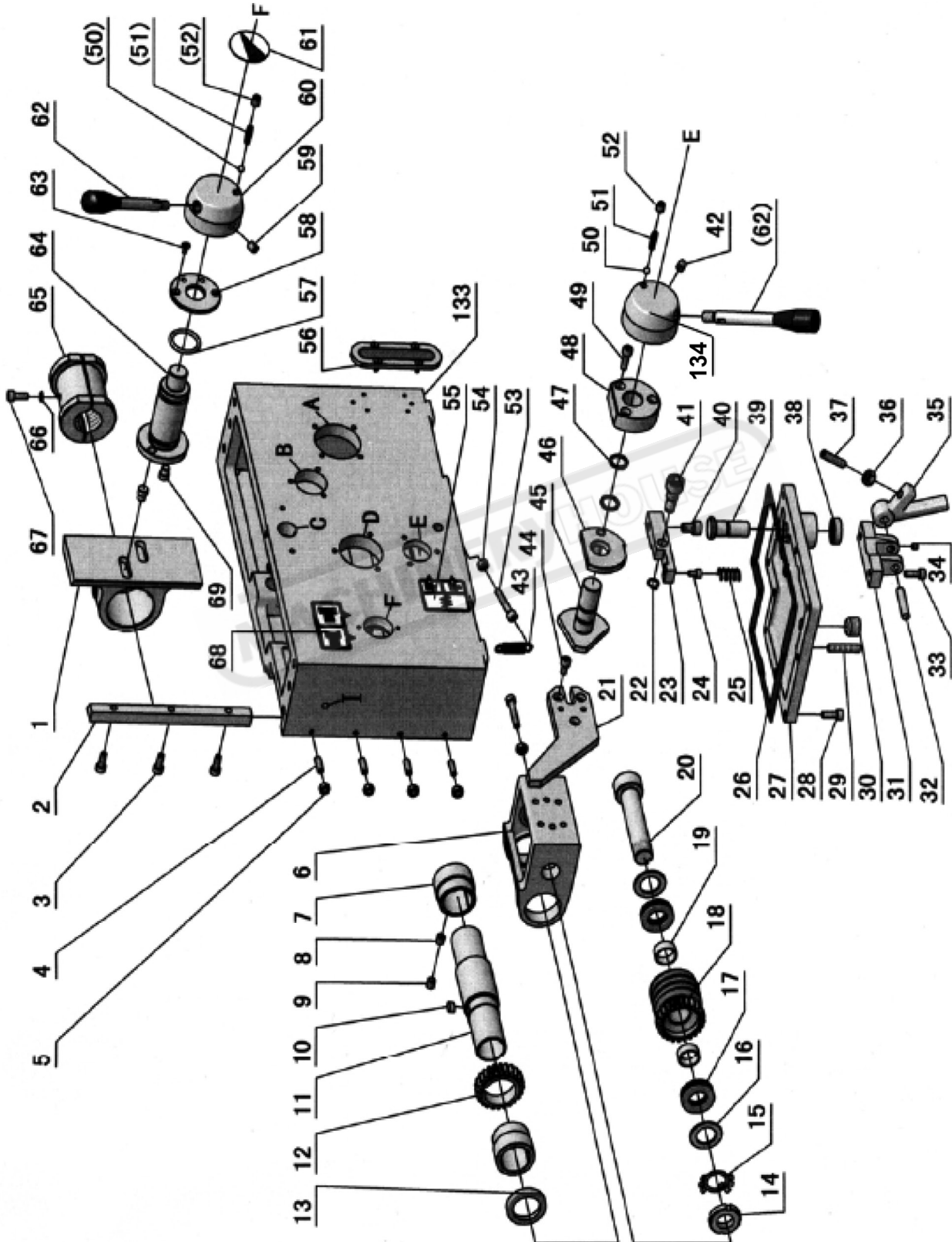

**APRON PARTS Cont.**

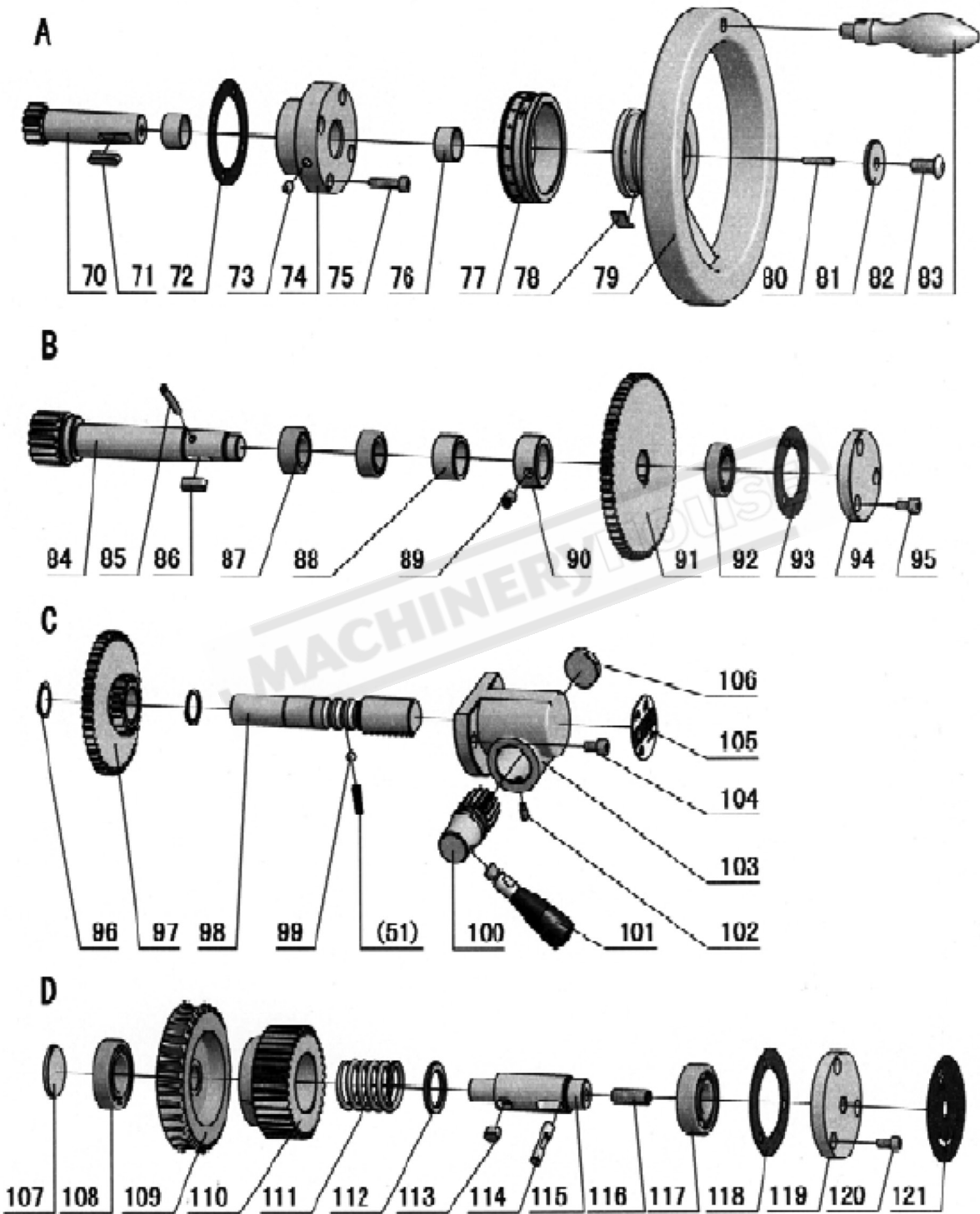

APRON PARTS Cont.

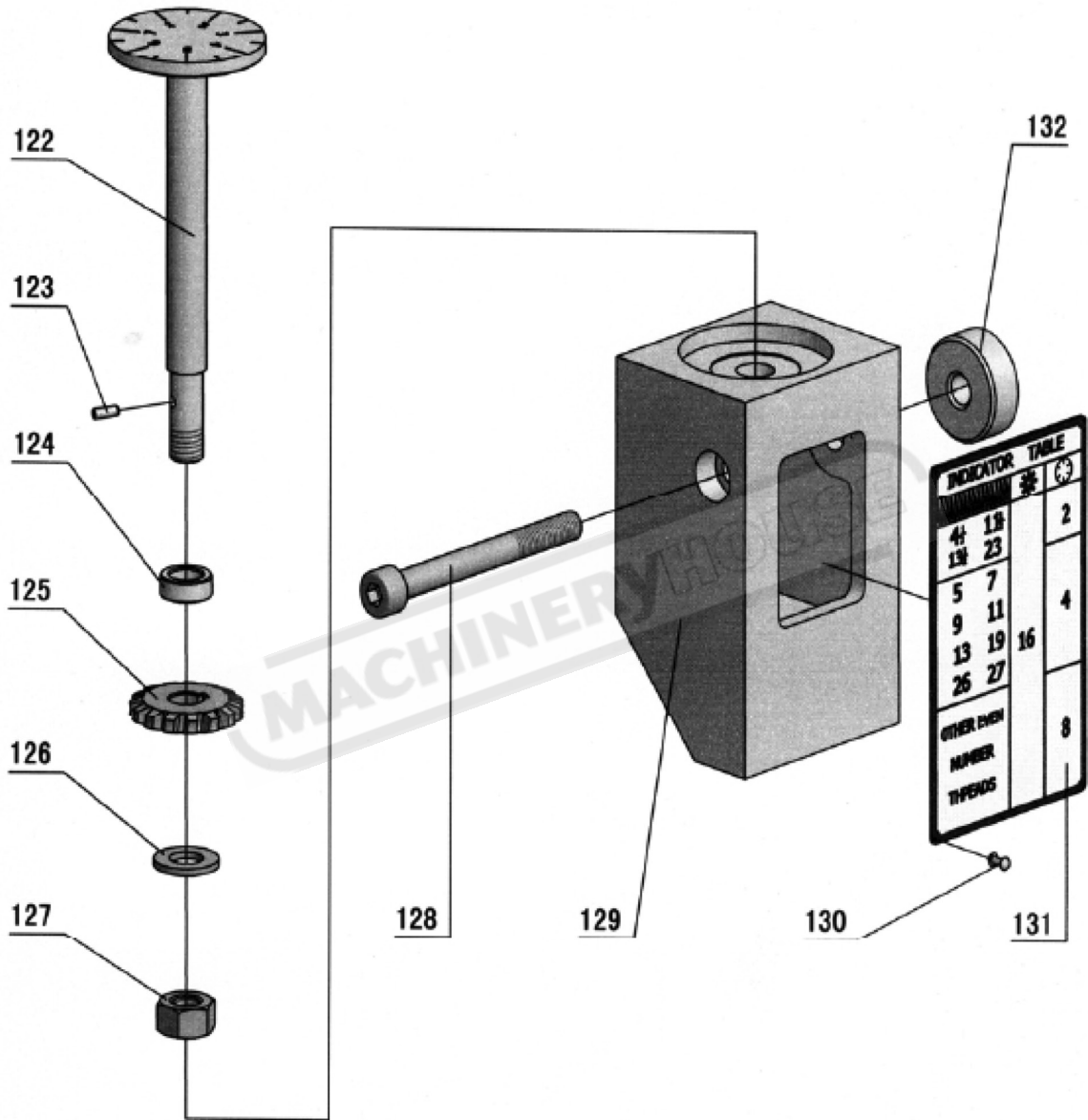

**OPERATION MANUAL**

**APRON PARTS LIST**

No	Part No.	Item	Specification	Qty.
1	RUN460-104003A	Lead Nut Assy (Right Hand)		1
1	RUN460-104003B	Lead Nut Assy (Left Hand)		1
2	RUN460-104002	Gib		1
3	GB70-85	Screw	M6×16	3
4	GB80-85	Screw	M6×20	4
5	GB6170-86	Nut	M6	4
6	RUN460-104018-01	Seat-Worm		1
7	RUN460-104015	Bushing		2
8	GB80-85	Screw	M8×10	2
9	GB77-85	Screw	M8×10	2
10	GB1096-79	Key	6×12	1
11	RUN460-104016	Sleeve-Feed Rod		1
12	RUN460-104017	Gear		1
13		Oil Seal	TC32×42×8	2
14	GB812-88	Nut	M20×1.5	1
15	GB858-88	Nut	20	1
16	RUN6246-104020/1	Washer		2
17	GB301-84	Thrust Bearing	8104	2
18	RUN460-104020	Worm Gear		1
19	CB85-2010	Set	20	2
20	RUN6246-104019	Shaft		1
21	RUN460-104023-01	Safe Device Block (Right Hand)		1
21	RUN460-104023-02	Safe Device Block (Left Hand)		1
22	GB894.1-86	Snap Ring	10	1
23	RUN460-104030	Lever		1
24	GB70-85	Screw	M5×8	1
25	RUN460-104032	Spring		1
26	RUN460-104011	Bottom Cover		1
27	RUN460-104011-1	Sealed Mat		1
28	GB70-85	Screw	M6×16	9
29	GB77-85	Screw	M6×35	1
30	G38-3A	Oil Plug	Z 3/8"	1
31	RUN460-104012	Bracket		1
32	GB119-86	Pin	B8×40	1
33	GB70-85	Screw	M6×16	2
34	GB80-85	Screw	M6×6	1
35	RUN460-104014	Lever		1
36	GB77-85	Screw	M8×30	1
37	GB6170-86	Nut	M8	1
38		Oil Seal	TC15×25×7	1

**APRON PARTS LIST Cont.**

No	Part No.	Item	Specification	Qty.
39	RUN460-104010	Pin		1
40	GB70-85	Screw	M8×12	1
41	RUN460-104031	Screw		1
42	GB80-85	Screw	M8×10	1
43	RUN460-104022-01	Spring		1
44	GB70-85	Screw	M6×12	3
45	RUN460-104026-01	Shaft (Right Hand)		1
45	RUN460-104026-02	Shaft (Left Hand)		1
46	RUN460-104027-H02	Buffer (Right Hand)		1
46	RUN460-104027-H01	Buffer (Left Hand)		1
47	GB1235-76	O-Ring	20×24	2
48	RUN460-104028	Sleeve		1
49	GB70-85	Screw	M6×20	3
50	GB308-84	Steel Ball	1/4"	2
51	RUN6246-101066	Spring		3
52	GB77-85	Screw	M8×10	2
53	GB70-85	Screw	M6×35	2
54	GB6170-86	Nut	M6	2
55	RUN6246-104074	Knob (Right Hand)		1
55	RUN6246-104074-2	Knob (Left Hand)		1
56	RUN460-104068	Oil Sight		1
57	GB1235-76	O-Ring	32×35	2
58	RUN460-104007/1	Washer		1
59	GB80-85	Screw	M8×10	1
60	RUN460-104007-02	Shaft Sleeve (Right Hand)		1
60	RUN460-104007-01	Shaft Sleeve (Left Hand)		1
61	RUN6246-101099	Plate		1
62	RUN460-104008	Lever		2
63	GB819-85	Screw	M4×10	2
64	RUN460-104006-01	Shaft (Right Hand)		1
64	RUN460-104006-02	Shaft (Left Hand)		1
65	RUN6246-104004-01	Haft Nut (Metric)		1
65	RUN6246-104004-02	Haft Nut (Inch)		1
66	GB93-87	Spring Pin	6	2
67	GB70-85	Screw	M6×16	2
68	RUN460-104073	Plate (Right Hand)		1
68	RUN460-104073-1	Plate (Left Hand)		1
69	RUN460-104005	Key	6×25	2
70	RUN460-104051	Shaft		1
71	GB1096-79	Key		1

**OPERATION MANUAL**

**APRON PARTS LIST Cont.**

No	Part No.	Item	Specification	Qty.
72	RUN460-104052-1	Sealed Mat		1
73	GB1155-89	Ball Cup	6	1
74	RUN460-104052	Seat		1
75	GB70-85	Screw	M6×25	4
76	SF-1	Bearing	2010	2
77	RUN460-104054-01	Dial-Rack (Metric)		1
77	RUN460-104054-02	Dial-Rack (Inch)		1
78	Q67-4-33	Spring	80	1
79	RUN460-104055	Hand Wheel		1
80	GB77-85	Screw	M4×20	1
81	RUN460-104057	Washer		1
82	RUN6246-101088	Screw		1
83	RUN460-104056A	Handle		1
84	RUN460-104047	Pinon		1
85	GB879-86	Pin	5×35	1
86	GB1096-79	Key	6×20	1
87	GB5801-86	Needle Bearing	4644903	2
88	RUN460-104053	Sleeve		1
89	GB80-85	Screw	M8×12	1
90	RUN460-104048	Spacer		1
91	RUN460-104049	Gear		1
92	GB278-89	Ball Bearing	80103	1
93	RUN460-104050-1	Sealed Mat		1
94	RUN460-104050	Cover		1
95	GB70-85	Screw	M6×12	3
96	GB894.1-86	Snap Ring	20	2
97	RUN460-104041	Gear		1
98	RUN460-104042	Shaft		1
99	GB308-84	Steel Ball	7/32"	1
100	RUN460-104044	Change Gear		1
101	RUN460-104045	Handle Lever		1
102	GB79-85	Screw	M5×10	1
103	RUN460-104043	Change Sleeve		1
104	GB70-85	Screw	M6×12	2
105	RUN460-104077	Plate		1
106	RUN460-104043/1	Plug		1
107	RUN460-104036-1	Cover		1
108	GB278-89	Ball Bearing	180105	1
109	RUN460-104034	Worm Gear		1
110	RUN460-104035	Gear		1

**APRON PARTS LIST Cont.**

No	Part No.	Item	Specification	Qty.
111	RUN460-104038	Spring		1
112	RUN460-104039	Spacer		1
113	GB1096-79	Key	8×12	1
114	RUN460-104037	Pin		1
115	RUN460-104036	Cover		1
116	GB77-85	Screw		1
117	GB278-89	Ball Bearing	80204	1
118	RUN460-104040-1	Sealed Mat		1
119	RUN460-104040	Cover		1
120	GB70-85	Screw	M6×12	3
121	RUN6246-104072	Plate		1
122	RUN460-104059B	Dial Indicator Shaft (Metric)		1
122	RUN460-104059A	Dial Indicator Shaft (Inch)		1
123	GB879-86	Pin	3×8	1
124	RUN460-104046	Spacer		1
125	RUN460-104061	Gear (Metric)		1
125	RUN460-104062	Gear (Metric)		1
125	RUN460-104063	Gear (Inch)		1
125	RUN460-104066	Gear (Metric)		1
125	RUN460-104067	Gear (Metric)		1
126	GB97.2-85	Washer	10	1
127	GB6170-86	Nut	M10	1
128	GB70-85	Screw	M8×85	1
129	RUN460-104058	Thread Dial Body		1
130	GB827-86	Rivet	2×5	10
131	RUN6246-104071	Indicator Dial (Metric)		1
131	RUN6246-104071-1	Indicator Dial (Inch)		1
132	RUN460-104024	Spacer		1
133	RUN6246-104001A	Apron (Right Hand)		1
133	RUN460-104001B	Apron (Left Hand)		1
134	RUN460-104029-01	Hub (Right Hand)		1
134	RUN460-104029-02	Hub (Left Hand)		1

**TAILSTOCK PARTS**

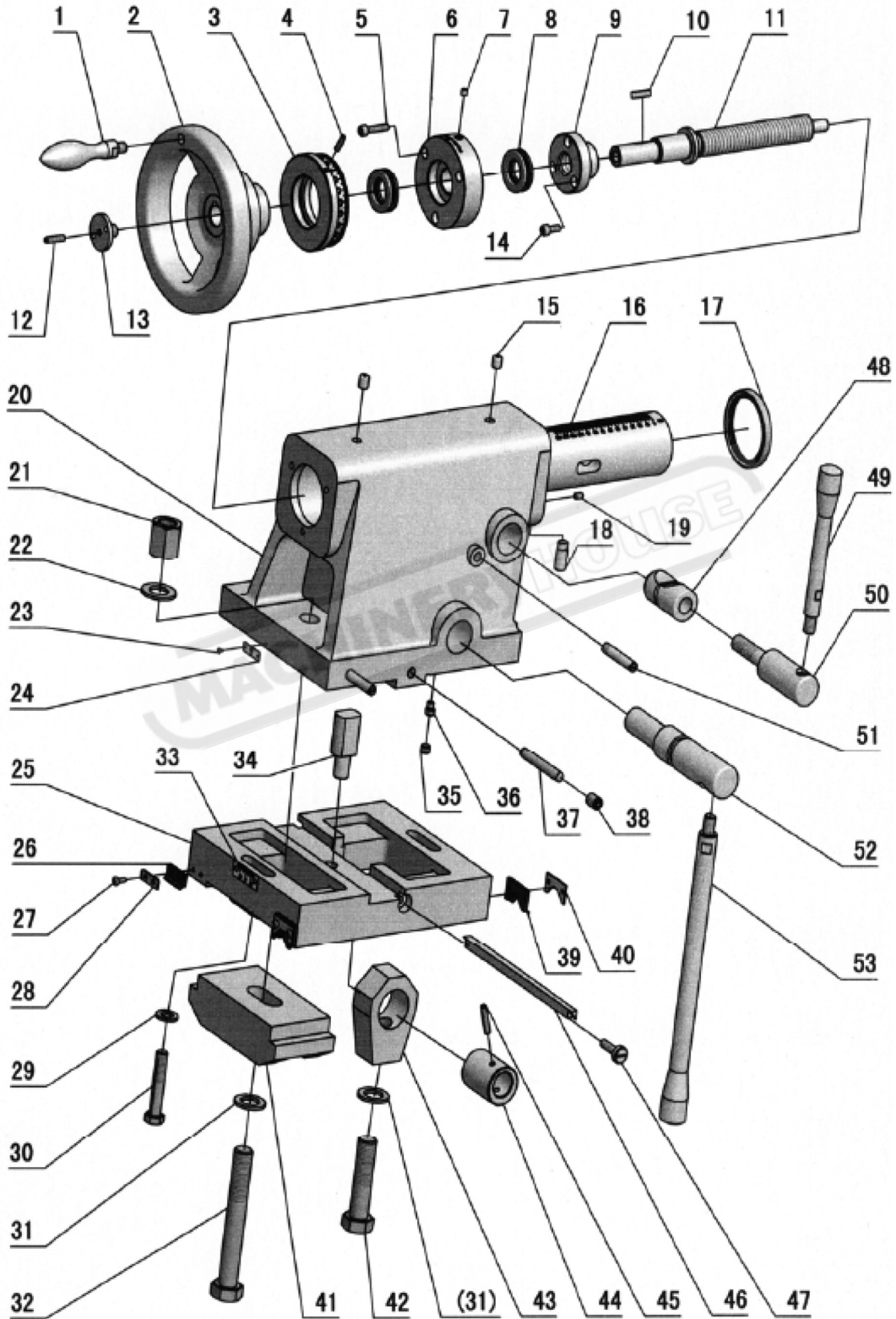

**TAILSTOCK PARTS LIST**

No	Part No.	Item	Specification	Qty.
1	RUN460-104056A	Handle		1
2	RUN6141-105014	Handwheel		1
3	RUN6141-105013	Dial-Feed (Metric)		1
3	RUN6141-105013-1	Dial-Feed (Inch)		1
4	GB80-85	Screw	M5×20	1
5	GB70-85	Socket Head Cap Screw	M6×30	3
6	RUN6141-105012	Cap-Body End (Metric)		1
6	RUN6141-105012-1	Cap-Body End (Inch)		1
7	GB1155-79	Ball Cup	6	1
8	GB301-84	Thrust Bearing	8105	2
9	RUN6141-105010	Nut (Metric)		1
9	RUN6141-105010-1	Nut (Inch)		1
10	GB1096-79	Key	6×25	1
11	RUN6141-105011	Screw-Spindle Feed (Metric)		1
11	RUN6141-105011-1	Screw-Spindle Feed (Inch)		1
12	GB80-85	Socket Botton Head Screw	M6×25	1
13	RUN6141-105016	Lock Nut		1
14	GB70-85	Screw	M6×16	3
15	GB1155-79	Ball Cup	10	2
16	RUN6141-105009	Spindle-Tang Slot		1
17	HG4-692-67	Oil-Seal	PD60×75×9	1
18	RUN6246-105029	Pin		1
19	GB80-85	Screw	M6×10	1
20	RUN6141-105001	Tailstock Body		1
21	GB55-88	Nut	M20	1
22	GB97.1-85	Washer	20	1
23	RUN460-105031	Plate		1
24	GB827-86	Rivet	2×5	4
25	RUN6141-105027	Bottom Tailstock		1
25	RUN6246H-105027	Bottom Tailstock		1
26	RUN6141-105022	Wiper		2
27	GB818-85	Cross Recessed Head Screw	M4×12	8
28	RUN6141-105021	Case-Wiper		2
29	GB95-76	Washer	12	2
30	GB5782-86	Bolt (C6241)	M12×65	2
30	GB5782-86	Bolt (C6246H)	M12×90	2
31	GB848-85	Washer	20	1
32	GB5782-86	Bolt (C6241)	M20×135	1
32	GB5782-86	Bolt (C6246H)	M20×160	1
33	RUN460-105032	Plate		1

**TAILSTOCK PARTS LIST Cont.**

<b>No</b>	<b>Part No.</b>	<b>Item</b>	<b>Specification</b>	<b>Qty.</b>
34	RUN460-105017	Block-Adjusting		1
35	GB77-86	Screw	M10×8	1
36	GB79-85	Screw	M10×12	1
37	GB119-86	Pin	B-10×70	2
38	GB80-85	Screw	M12×16	2
39	RUN6141-105024	Wiper		2
40	RUN6141-105023	Case-Wiper		2
41	RUN6141-105025	Clamp		1
41	RUN6141-105025A	Clamp		1
42	GB5782-86	Bolt (C6241)	M20×80	1
42	GB5782-86	Bolt (C6246H)	M20×110	1
43	RUN460-105018	Bracket		1
44	RUN460-105028	Eccentric Block		1
45	GB879-86	Spring Pin	6×36	1
46	RUN6141-105019	Gip		1
47	RUN460-105020	Screw		1
48	RUN6141-105002	Shaft Lock Sleeve		1
49	RUN460-105004	Lead Screw		1
50	RUN6141-105003	Lock Bolt		1
51	RUN6246-105007	Screw-Brake		2
52	RUN6141-105005	Shaft		1
53	RUN460-105006	Lead Screw		1

**BED ASSEMBLY PARTS**

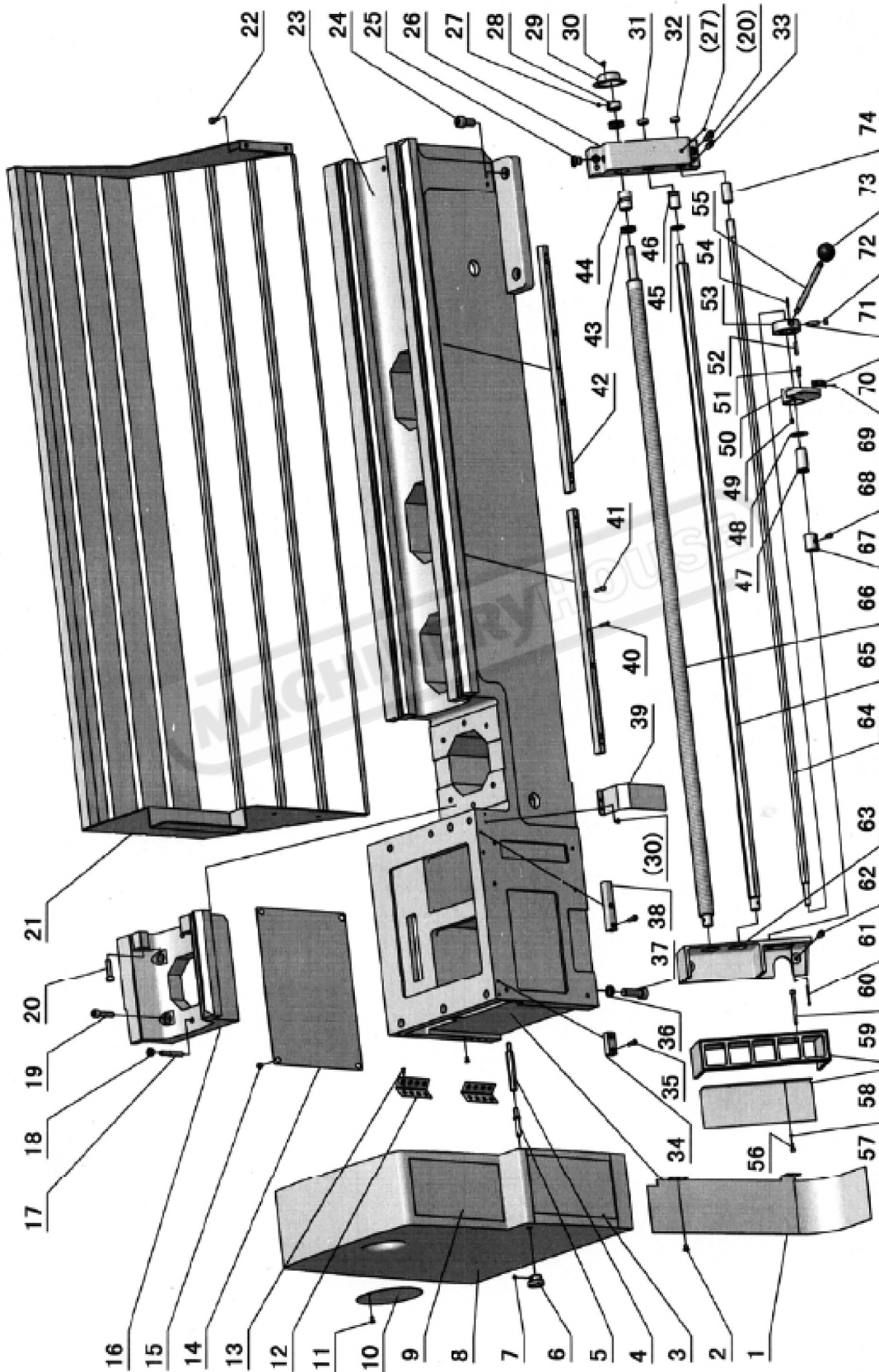

**BED ASSEMBLY PARTS Cont.**

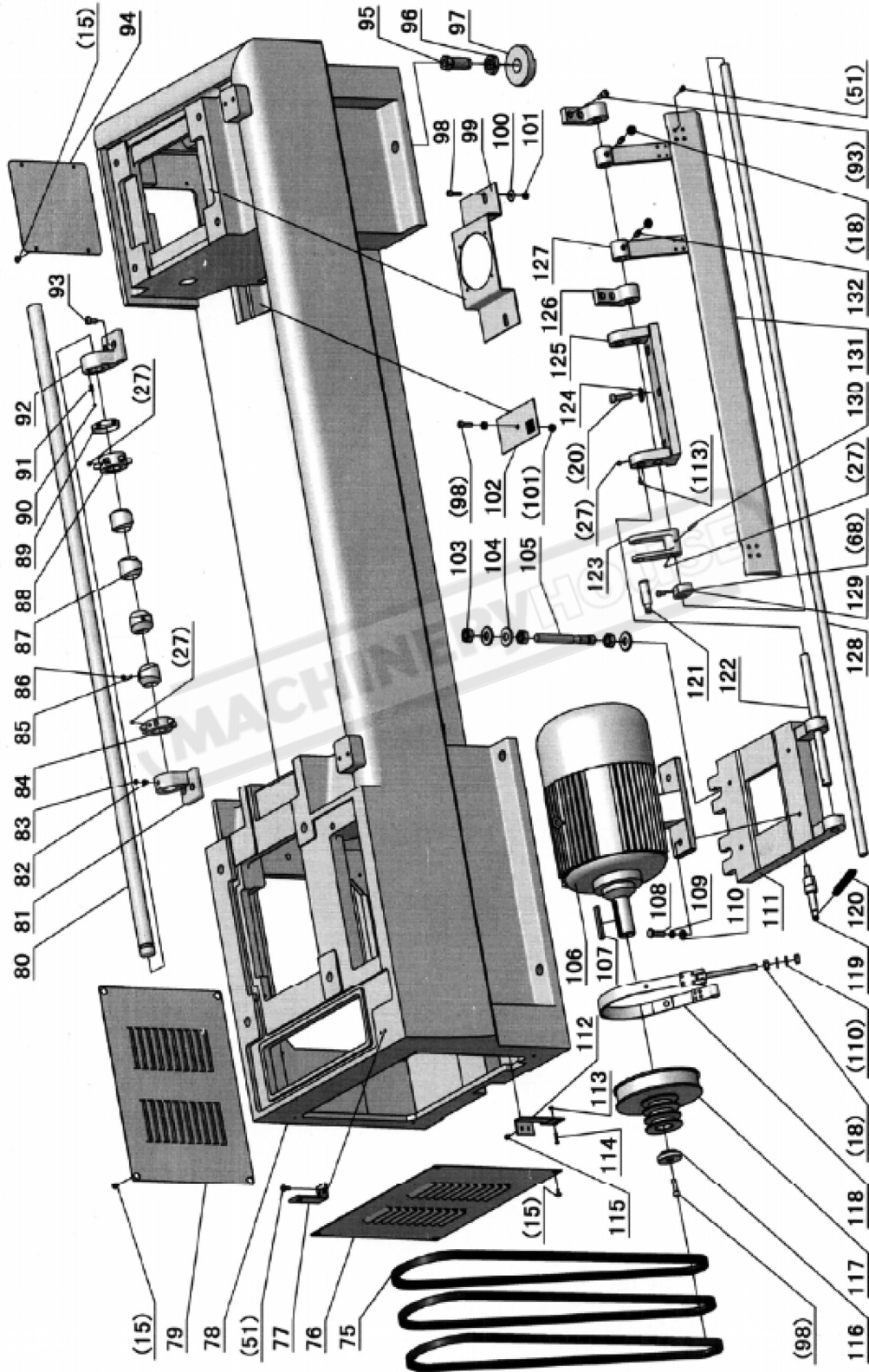

**BED ASSEMBLY PARTS Cont.**

**METRIC**

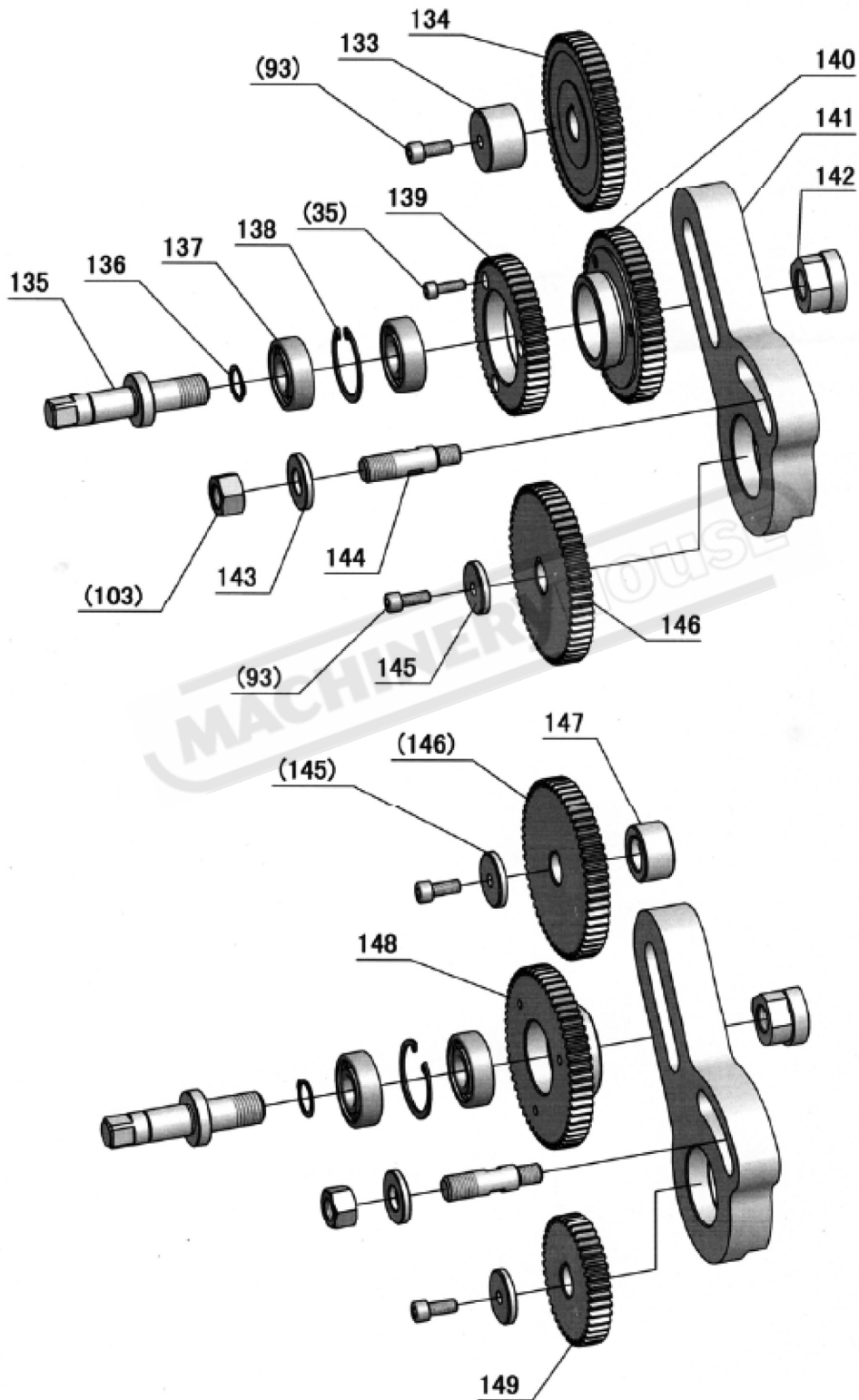

**BED ASSEMBLY PARTS Cont.**

INCH

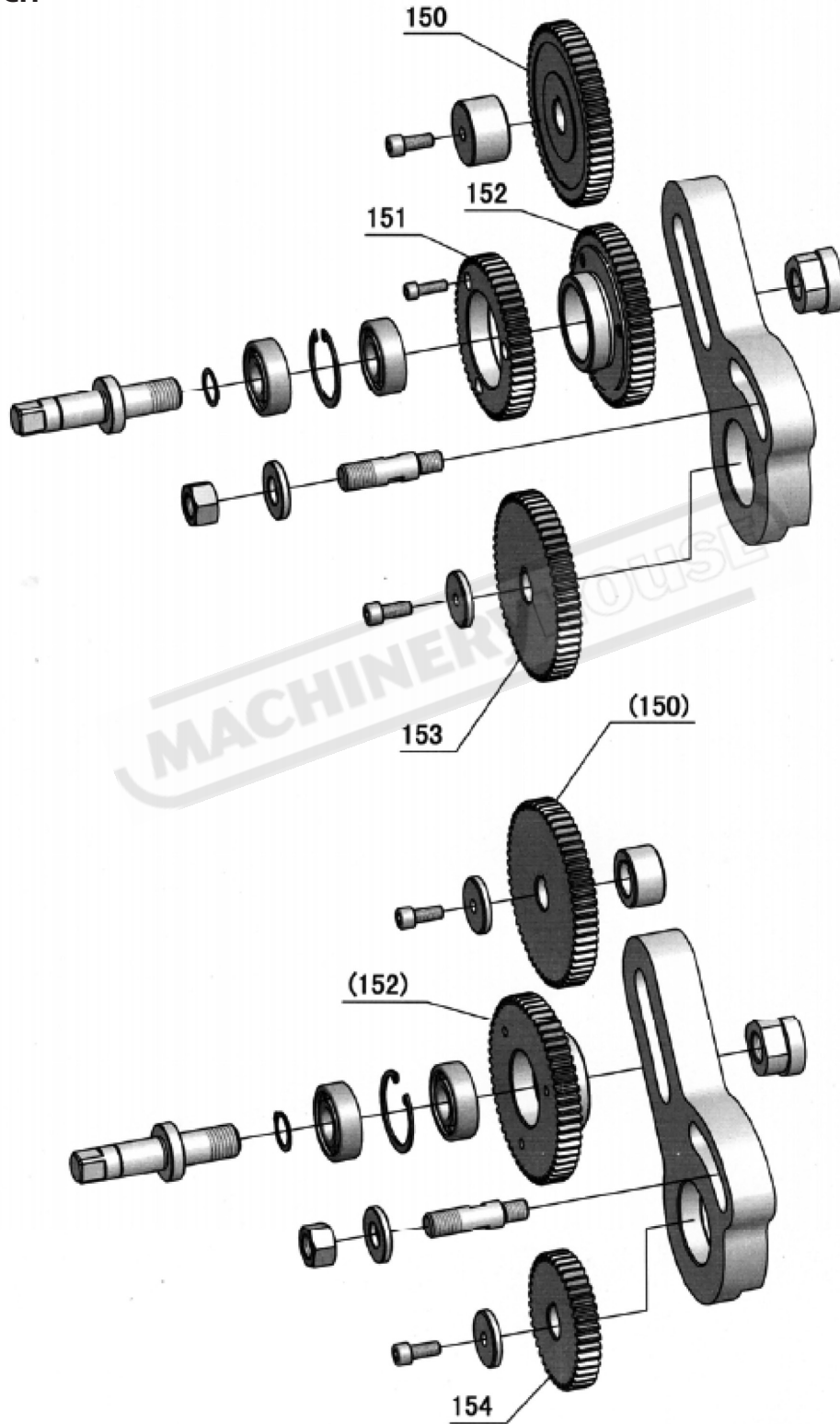

**BED ASSEMBLY PARTS LIST**

No	Part No.	Item	Specification	Qty.
1	RUN6246-108098	Oil Guard		1
2	GB70-85	Screw	M6×10	2
3	RUN6246-108094	Plate		1
4	RUN6246-108082	Bolt		1
5	RUN6246-108074	Screw		1
6	RUN6246-108073	Nut		1
7	GB79-85	Screw	M6×8	1
8	RUN6141-108032	Cover-End (C6241)		1
8	RUN6246H-108032	Cover-End (C6246h)		1
9	RUN6141-108024	Plate (Metric)		1
9	RUN6141-108025	Plate (Inch)		1
9	RUN6246H-108024	Plate (Metric)		1
10	C6251A-04-05	Cover		1
11	GB/T70.2-2000	Screw	M6×10	1
12	GB7277-87	Hinge	100	2
13	GB68-85	Screw	M5×10	16
14	RUN6246-106071	Electric Cover		1
15	GB818-85	Screw	M6×10	16
16	RUN6141-106002	Saddle		1
17	GB118-86	Pin	10×70	2
18	GB6170-86	Nut	M10	6
19	GB70-85	Screw	M12×50	4
20	GB70-85	Screw	M10×40	7
21	RUN6246-106072A	Guard Assembly 1000		1
21	RUN6246-106072B	Guard Assembly 1500		1
21	RUN6246-106072C	Guard Assembly 2000		1
22	GB70-85	Screw	M8×16	4
23	RUN6241-106001	Bed 1000		1
23	RUN6241-106001-1	Bed 1500		1
23	RUN6241-106001-3	Bed 2000		1
24	GB70-85	Screw	M16×35	4
25	RUN6246-106010-4	Plug-Oil Inlet		1
26	RUN6246-106010	Bracket		1
27	GB80-85	Screw	M6×8	6
28	RUN6246-106007	Nut		1
29	RUN6246-106031	Cover		1
30	GB818-85	Screw	M5×8	5
31	RUN6246-106010-1	Plug		1
32	RUN6246-106010-2	Plug		1
33	GB118-86	Taper Pin	10×45	2

**BED ASSEMBLY PARTS LIST Cont.**

No	Part No.	Item	Specification	Qty.
34	RUN6141-106095	Block		1
35	GB70-85	Screw	M6×20	7
36	GB93-86	Spring Washer	16	4
37	GB70-85	Screw	M16×55	4
38	RUN6141-106094	Block		1
39	RUN6246-106009	Protection Cover		1
40	GB879-86	Spring Pin	5×30	6
41	GB70-85	Screw	M6×25	8
42	RUN6246-106005B	Rack		1
42	RUN6246-106005C	Rack		1
42	RUN6246-106005D	Rack (Left Hand)		1
43	GB301-84	Thrust Bearing	8104	2
44	RUN6246-106010-6	Sleeve		1
45	RUN6246-106010-7	Spacer		1
46	RUN6246-106008	Bush		1
47	RUN6246-106056	Shaft Sleeve		1
48	RUN6246-106058	Washer		1
49	Q81-1	Spring	1×6×20	3
50	RUN6246-106059	Switch Bracket		1
51	GB70-85	Screw	M6×16	12
52	RUN6246-106055	Pin	3×20	1
53	RUN6246-106053	Bracket	M5×10	1
54	GB879-86	Spring Pin	5	1
55	RUN6246-106057A	Lever		1
56	GB70-85	Screw		2
57	GB93-87	Washer		2
58	RUN6141-106018-1	Cover		1
59	RUN6141-106018	Seat-Pilot Light		1
60	GB70-85	Screw	M6×70	2
61	GB70-85	Screw	M4×40	2
62	GB70-85	Screw	M8×25	2
63	RUN6246-106016	Seat-Switch		1
64	RUN6246-106015	Started Rod 1000		1
64	RUN6246-106015-1	Started Rod 1500		1
64	RUN6246-106015-3	Started Rod 2000		1
65	RUN6246-106013	Feed Rod 1000		1
65	RUN6246-106013-1	Feed Rod 1500		1
65	RUN6246-106013-3	Feed Rod 2000		1
66	RUN6246-106006A	Lead Screw 1000(Inch)		1
66	RUN6246-106006B	Lead Screw 1000(Metric)		1

**BED ASSEMBLY PARTS LIST Cont.**

No	Part No.	Item	Specification	Qty.
66	RUN6246-106006C	Lead Screw 1500(Inch)		1
66	RUN6246-106006D	Lead Screw 1500(Metric)		1
66	RUN6246-106006G	Lead Screw 2000(Inch)		1
66	RUN6246-106006H	Lead Screw 2000(Metric)		1
67	CM6233-2055	Cam		1
68	GB70-85	Screw	M6×12	2
69	GB827-86	Screw	2×5	2
70	RUN6246-106089	Plate		1
71	GB79-85	Screw	M8×30	2
72	GB6170-86	Nut	M8	2
73	Z16-1	Lever Bush	M12×40	1
74	RUN6246-106014	Bush		1
75	C6141 7.5HP/60HZ	Belt B73	B73	3
75	C6141 7.5HP/50HZ	Belt B74	B74	3
75	C6246H 7.5HP/60HZ	Belt B75	B75	3
75	C6246H 7.5HP/50HZ	Belt B76	B76	3
76	RUN6246-106028	Cover Motor Seat		1
77	RUN6246-108078	Limited Switch Seat		1
78	RUN6246-106003	Stand 1000		1
78	RUN6246-106003-1	Stand 1500		1
78	RUN6246-106003-3	Stand 2000		1
79	RUN6246-106028-1	Cover Motor Seat		1
80	RUN6246-106019	Auto Stopping Shaft 1000		1
80	RUN6246-106019-3	Auto Stopping Shaft 1500		1
80	RUN6246-106019-6	Auto Stopping Shaft 2000		1
81	RUN6141-106024	Bracket		1
82	GB79-85	Screw	M8×12	1
83	GB77-85	Screw	M8×6	1
84	RUN6246-106019-1	Star Type Ring		1
85	RUN6246-106020-1	Shoe Clamp		4
86	GB80-85	Screw	M8×6	4
87	RUN6246-106020	Cam		4
88	RUN6246-106019-2	Star Type Ring		1
89	RUN6246-106019-5	Plate		1
90	GB308-84	Steel Ball	6	1
91	Q81-1	Spring	1×5×25	1
92	RUN6141-106025	Bracket		1
93	GB70-85	Screw	M8×20	10
94	RUN6246-106033	Pump Hole Cover		1
95	RUN6246-106029	Bolt		6

**OPERATION MANUAL**

**BED ASSEMBLY PARTS LIST Cont.**

No	Part No.	Item	Specification	Qty.
96	GB6173-86	Nut	M24×2	6
97	RUN6246-106069	Block-Leveling		6
98	GB70-85	Screw	M8×30	4
99	RUN6246-106090A	Coolant Pump Seat		1
100	GB96-85	Washer	8	2
101	GB6170-86	Nut	M8	4
102	RUN6246-106051	Screen		1
103	GB6170-86	Nut	M16	7
104	RUN6246-106079	Washer		6
105	RUN6246-106046	Screw		2
106		Motor	5.5kw	1
107	GB1096C-79	Key	10×70	1
108	GB5782-86	Bolt	M10×35	4
109	GB93-87	Spring Washer	10	4
110	GB97.1-85	Washer	10	6
111	RUN6246-106034	Motor Seat		1
112	RUN6246-106091	Limited Switch Seat		1
113	GB6170-86	Nut	M4	2
114	GB818-85	Screw	M4×20	2
115	GB70-85	Screw	M5×8	3
116	RUN6141-106049a	Washer		1
117	RUN6141-106048a	Belt Pulley	60Hz	1
117	RUN6141-106048a-1	Belt Pulley	50Hz	1
118	RUN6246-106047	Belt-Brake		1
119	RUN6246-106050	Shaft		1
120	Q81-3	Spring	3×16×115	1
121	RUN6246-106039	Shaft		1
122	RUN6246-106044	Shaft		1
123	RUN6246-106040	Arm Brake		1
124	RUN6246-106097	Washer		3
125	RUN6246-106041	Bracket-Motor Seat		1
126	RUN6246-106036	Bracket		2
127	RUN6246-106042A	Arm		2
128	RUN6246-106045	Shaft 1000		1
128	RUN6246-106045-1	Shaft 1500		1
128	RUN6246-106045-3	Shaft 2000		1
129	RUN6246-106037	Cam		1
130	GB879-86	Spring Pin	5×40	1
131	RUN6246-106040D	Pedal-Bracket 1000		1
131	RUN6246-106040E	Pedal-Bracket 1500		1

**BED ASSEMBLY PARTS LIST Cont.**

<b>No</b>	<b>Part No.</b>	<b>Item</b>	<b>Specification</b>	<b>Qty.</b>
131	RUN6246-106040H	Pedal-Bracket 2000		1
132	GB79-85	Screw	M10×25	2
133	RUN6141-108002	Spacer		1
134	RUN6141-108001	Gear (Metric)	55T×M2	1
135	RUN6141-108004	Bolt		1
136	GB894.1-86	Snap Ring	20	1
137	GB278-89	Ball Bearing	180204	2
138	GB893.1-86	Snap Ring	47	1
139	RUN6141-108003	Gear (Metric)	49T×M2	1
140	RUN6141-108006	Gear (Metric)	54T×M2	1
141	RUN6141-108009	Bracket		1
142	RUN6141-108005	Nut		1
143	RUN6141-108017	Washer		1
144	RUN6246-108063	Bolt		1
145	RUN6141-108007	Spacer		1
146	RUN6141-108008	Gear (Metric)	56T×M2	1
147	RUN6141-108015	Spacer		1
148	RUN6141-108010	Gear (C6241 Metric)	57T×M2	1
148	RUN6246H-108010-1	Gear (C6246h Metric)	64T×M2	1
149	RUN6141-108011	Gear (Metric)	40T×M2	1
150	RUN6141-108012	Gear (Inch)	48T×M2	1
151	RUN6141-108013	Gear (Inch)	66T×M2	1
152	RUN6141-108010	Gear (Inch)	57T×M2	1
153	RUN6141-108014	Gear (Inch)	42T×M2	1
154	RUN6141-108016	Gear (Inch)	57T×M2	1

**FIXED STEADY PARTS**

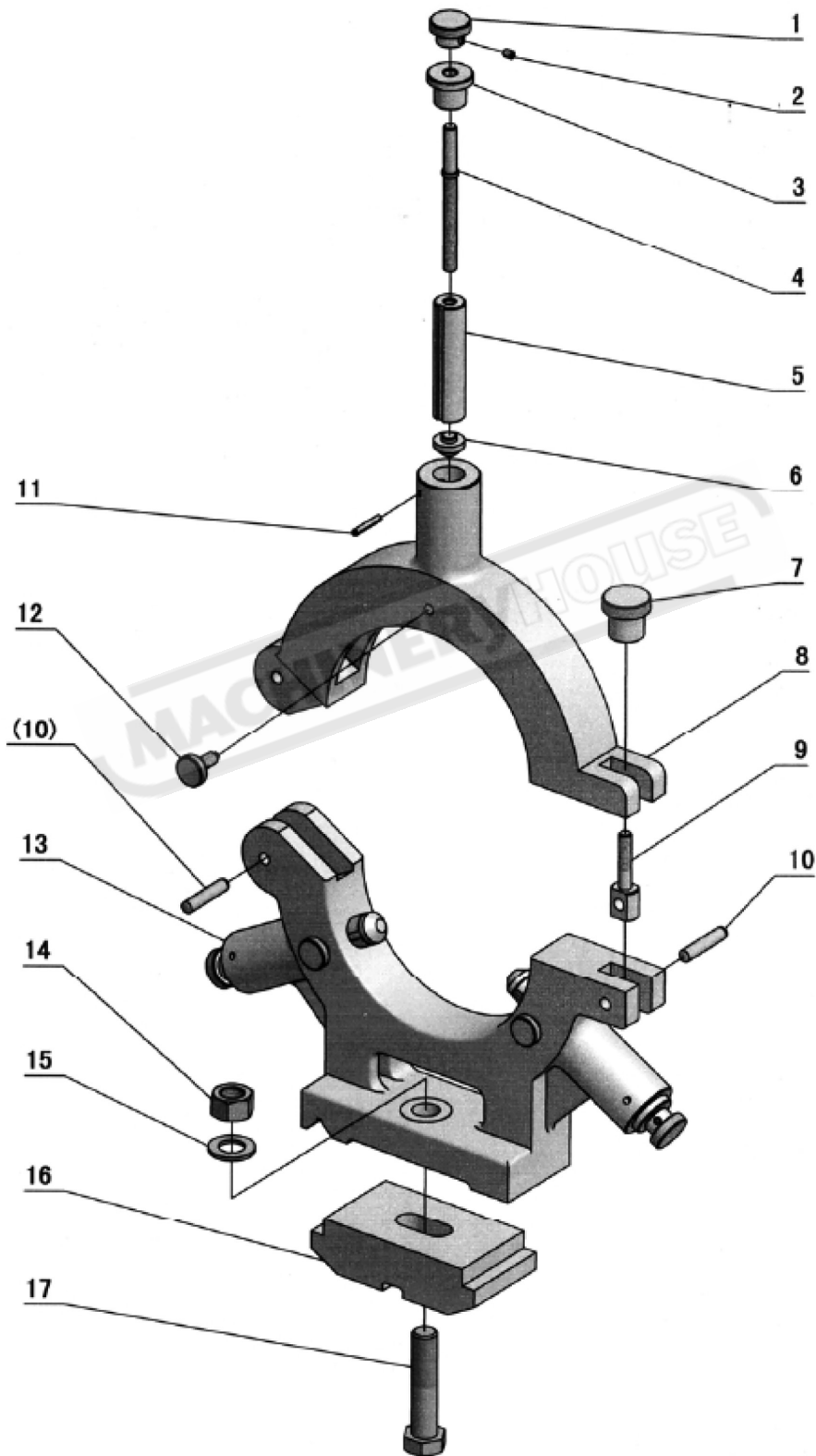

**FIXED STEADY PARTS LIST**

No	Part No.	Item	Specification	Qty.
1	RUN6246-110019	Rotate Handle		3
2	GB78-85	Screw	M6×8	3
3	RUN6246-110004	Bush		3
4	RUN6141-110008	Screw Shaft		3
5	RUN6141-110010	Sleeve		3
6	RUN6246-110024	Bracket		1
7	RUN6246-110014	Handle		1
8	RUN6141-110002	Upside of Steady Rest		1
9	RUN6246-110013	Clamping Screw		1
10	GB119-86	Pin	10×50	1
11	GB879-86	Spring Pin	5×32	3
12	RUN6246-110018	Limited Screw		3
13	RUN6141-110001	Downside of Steady Rest		1
13	RUN6246H-110001	Downside of Steady Rest		1
14	GB6170-86	Nut	M20	1
15	GB97.1-85	Washer	20	1
16	RUN6141-105025A	Clamping Bracket		1
17	GB5780-86	Bolt	M20×90	1

**TRAVELING STEADY PARTS**

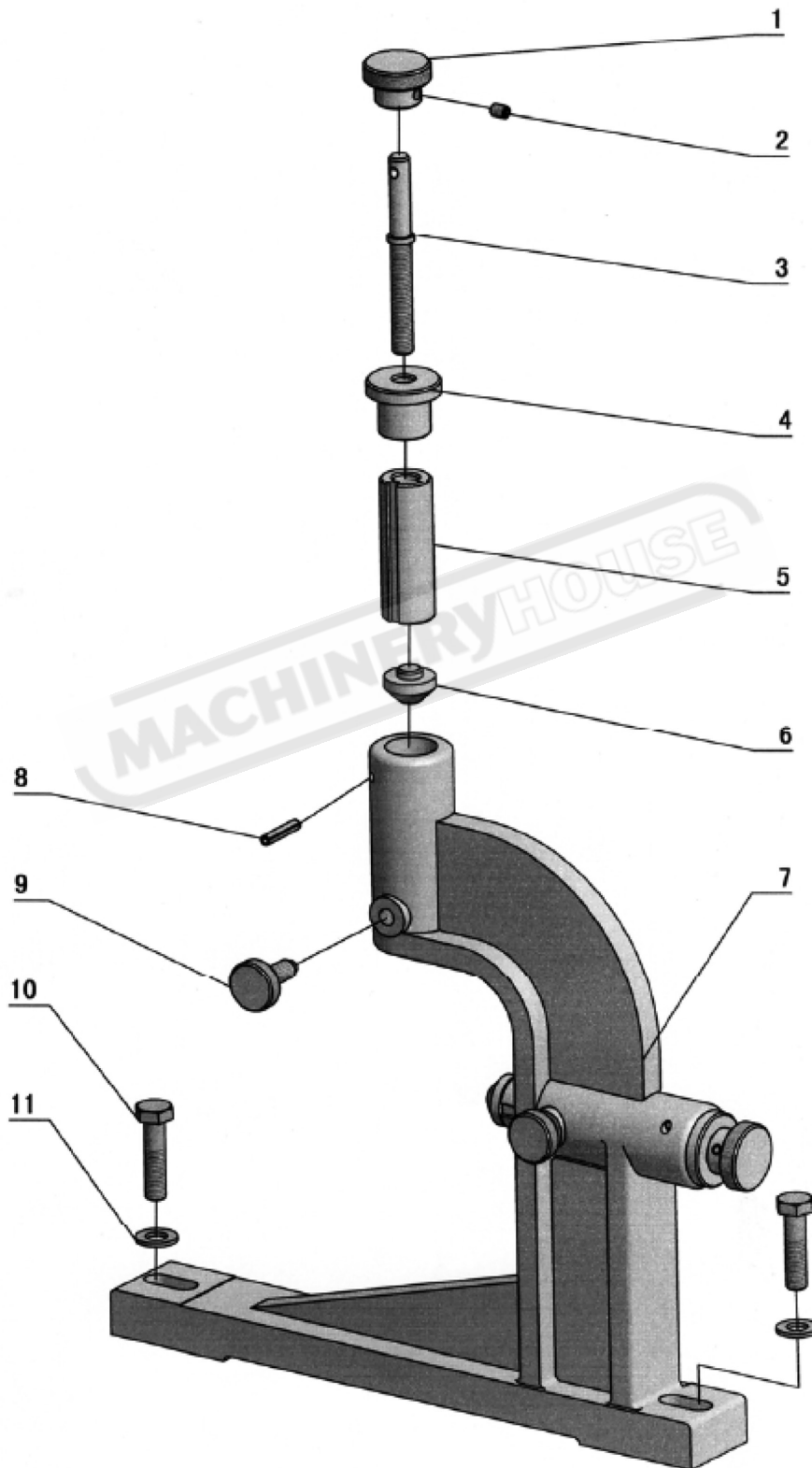

**TRAVELING STEADY PARTS LIST**

<b>No</b>	<b>Part No.</b>	<b>Item</b>	<b>Specification</b>	<b>Qty.</b>
1	RUN6246-110019	Rotate Handle		2
2	GB78-85	Screw		2
3	RUN6246-110015	Screw Shaft		2
4	RUN6246-110004	Bush		2
5	RUN6246-110016	Sleeve		2
6	RUN6246-110024	Bracket		2
7	RUN6141-110005	Follow Rest (C6241)		1
7	RUN6246H-110005	Follow Rest (C6246h)		1
8	GB879-86	Spring Pin	5×26	2
9	RUN6246-110018	Limited Screw		2
10	GB5782-86	Bolt	M10×40	2
11	GB97.1-85	Washer		2

MACHINERYHOUSE

# WARNING

## General Machinery Safety Instructions

---

Machinery House  
requires you to read this entire Manual before using this machine.

- 1. Read the entire Manual before starting machinery.** Machinery may cause serious injury if not correctly used.
- 2. Always use correct hearing protection when operating machinery.** Machinery noise may cause permanent hearing damage.
- 3. Machinery must never be used when tired, or under the influence of drugs or alcohol.** When running machinery you must be alert at all times.
- 4. Wear correct Clothing.** At all times remove all loose clothing, necklaces, rings, jewelry, etc. Long hair must be contained in a hair net. Non-slip protective footwear must be worn.
- 5. Always wear correct respirators around fumes or dust when operating machinery.** Machinery fumes & dust can cause serious respiratory illness. Dust extractors must be used where applicable.
- 6. Always wear correct safety glasses.** When machining you must use the correct eye protection to prevent injuring your eyes.
- 7. Keep work clean and make sure you have good lighting.** Cluttered and dark shadows may cause accidents.
- 8. Personnel must be properly trained or well supervised when operating machinery.** Make sure you have clear and safe understanding of the machine you are operating.
- 9. Keep children and visitors away.** Make sure children and visitors are at a safe distance for you work area.
- 10. Keep your workshop childproof.** Use padlocks, Turn off master power switches and remove start switch keys.
- 11. Never leave machine unattended.** Turn power off and wait till machine has come to a complete stop before leaving the machine unattended.
- 12. Make a safe working environment.** Do not use machine in a damp, wet area, or where flammable or noxious fumes may exist.
- 13. Disconnect main power before service machine.** Make sure power switch is in the off position before re-connecting.
- 14. Use correct amperage extension cords.** Undersized extension cords overheat and lose power. Replace extension cords if they become damaged.
- 15. Keep machine well maintained.** Keep blades sharp and clean for best and safest performance. Follow instructions when lubricating and changing accessories.
- 16. Keep machine well guarded.** Make sure guards on machine are in place and are all working correctly.
- 17. Do not overreach.** Keep proper footing and balance at all times.
- 18. Secure workpiece.** Use clamps or a vice to hold the workpiece where practical. Keeping the workpiece secure will free up your hand to operate the machine and will protect hand from injury.
- 19. Check machine over before operating.** Check machine for damaged parts, loose bolts, Keys and wrenches left on machine and any other conditions that may effect the machines operation. Repair and replace damaged parts.
- 20. Use recommended accessories.** Refer to instruction manual or ask correct service officer when using accessories. The use of improper accessories may cause the risk of injury.
- 21. Do not force machinery.** Work at the speed and capacity at which the machine or accessory was designed.
- 22. Use correct lifting practice.** Always use the correct lifting methods when using machinery. Incorrect lifting methods can cause serious injury.
- 23. Lock mobile bases.** Make sure any mobile bases are locked before using machine.
- 24. Allergic reactions.** Certain metal shavings and cutting fluids may cause an allergic reaction in people and animals, especially when cutting as the fumes can be inhaled. Make sure you know what type of metal and cutting fluid you will be exposed to and how to avoid contamination.
- 25. Call for help.** If at any time you experience difficulties, stop the machine and call you nearest branch service department for help.

# WARNING

## Metal Lathe Safety Instructions

---

Machinery House  
requires you to read this entire Manual before using this machine.

- 1. Maintenance.** Make sure the lathe is turned off and disconnect from the main power supply and make sure all moving parts have come to a complete stop before any inspection, adjustment or maintenance is carried out.
- 2. Lathe Condition.** Lathe must be maintained for a proper working condition. Never operate a lathe that has damaged or worn parts. Scheduled routine maintenance should be performed on a scheduled basis.
- 3. Leaving a Lathe Unattended.** Always shut the lathe off and make sure all moving parts have come to a complete stop before leaving the lathe. An unsupervised running lathe can cause serious injury.
- 4. Avoiding Entanglement.** Remove loose clothing, belts, or jewelry items. Tie up long hair and use the correct hair nets to avoid any entanglement with moving parts.
- 5. Chuck key safety.** Never let go of a chuck key while still in the chuck to prevent leaving the chuck key in the chuck. Chuck keys left in the chuck can cause serious injury.
- 6. Changing Chucks.** When changing large heavy chucks they become awkward to hold. Always get assistance when installing large chucks. Use a board or piece of plywood across the bedway when any install or removal of chucks to avoid any possible finger pinching between a loose chuck and edge of a bedway.
- 7. Tooling selection.** Always use the correct cutting tool for the job you are turning. Make sure it is sharp and held firmly in the tool post. Adjust the toolpost to provide proper support for the tool you will be using.
- 8. Mounting the workpiece.** Make sure the workpiece is properly mounted and secure before turning on the lathe. A loose workpiece can be thrown across the room and cause serious injury to you or a bystander.
- 9. Workpiece clearance.** Rotate the workpiece by hand to check for clearance with the tool post, compound slide and carriage before turning the lathe on.
- 10. Changing speeds and Reversing.** Turn the lathe off and make sure the lathe has come to a complete stop before changing speeds or reversing the spindle. Do not slow or stop the lathe chuck by using your hand.
- 11. Speed selection.** Select the appropriate speed for the type of work, material, and tool bit. Allow the lathe to reach full speed before beginning a cut.
- 12. Clearing chips.** Always use a brush to clear chips. Never clear chips when the lathe is running.
- 13. Power outage.** In the event of a power failure during use of the lathe, turn off all switches to avoid possible sudden start up once power is restored.
- 14. Clean work area.** Keep the area around the lathe clean from oil, tools and chips.
- 15. Call for help.** If at any time you experience difficulties, stop the machine and call your nearest branch service department for help.

## PLANT SAFETY PROGRAM

### **NEW MACHINERY HAZARD IDENTIFICATION, ASSESSMENT & CONTROL**

#### **Metal Lathe**

Developed in Co-operation Between A.W.I.S.A and Australia Chamber of Manufactures  
This program is based upon the Safe Work Australia, Code of Practice - Managing Risks of Plant in the Workplace ( WHSA 2011 No10 )

Item No.	Hazard Identification	Hazard Assessment	Risk Control Strategies <small>(Recommended for Purchase / Buyer / User)</small>
A	ENTANGLEMENT	HIGH	Eliminate, avoid loose clothing / Long hair etc.
C	CUTTING, STABBING, PUNCTURING	MEDIUM	Isolate power to machine prior to any checks or maintenance. Do not open or clean inside until the machine has completely stopped.
D	SHEARING	MEDIUM	Make sure all guards are secured shut when machine is on. Isolate power to machine prior to any checks or maintenance.
F	STRIKING	MEDIUM	Ensure workpiece is secured in chuck and tooling is locked tight in toolpost. Always wear safety glasses. Do not leave chuck key in chuck. Remove all loose objects around moving parts.
H	ELECTRICAL	MEDIUM	All electrical enclosures should only be opened with a tool that is not to be kept with the machine.
N	HIGH - TEMPERATURE	LOW	Machine should be installed & checked by a Licensed Electrician.
O	OTHER HAZARDS, NOISE.	LOW	Wear appropriate protective clothing to prevent hot swarf. Wear hearing protection as required.
Plant Safety Program to be read in conjunction with manufactures instructions			



[www.machineryhouse.com.au](http://www.machineryhouse.com.au)



[www.machineryhouse.co.nz](http://www.machineryhouse.co.nz)

Authorised and signed by:  
Safety officer:



Manager:



Revised Date: 12th March 2012